

Stock Code: 002438
Stock Abbr. JiangsuShentong



Ball Valve

Professional flow control solutions provider

Jiangsu Shentong Valve Co., Ltd.
Add: NanYang Industrial Zone, Qi Dong City,
Jiangsu Province
Tel : 86-21-3255 5823 86-139 13171496
Fax: 86-21-3255 5898
Mailbox: stv@stvalves.com.cn
Website: www.stfm.cn
Post Code: 200333

Distributed by:

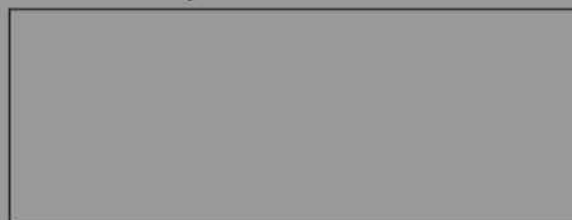

Directory

Brief Introduction

1. Overview
2. Technical Innovation
3. Advanced Manufacturing

Product Range

III. Floating Ball Valve

- 1-PC, Side entry
- 2-PC, Split body, side entry
- 3-PC, Split body, side entry

IV. Trunnion Mounted Ball Valve

- 2-PC, Split body, side entry
 - 3-PC, Split body, side entry
- Top entry, Cast steel design
Full Welded, Cast steel design



ISO 14001 : 2004



ISO 9001 : 2004



OHS Cer.



API607 Fire safety Cer. for Ball Valve



CE Cer.



GHOST-R Cer.



TS-Piping Parts Cer.



TS Piping Cer.



BV Cer.



API 6D



API 609



API600



API607 fire safety for Butterfly



Overview

As one of the professional industrial valve manufactures in China, STV always focuses on the continuous innovation to provide our customers reliable fluid control solutions. STV product line concentrate on both of commodity valve and high engineering valve with more than 90 serious and 2000 specs covering the different size and rating, high temperature and cryogenic service as well as other critical

STV plant covered area over 158,000 m², with a building area of 88,000 m². We have large number of vertical lathe, machining center, numerical control lathe etc sophisticated machining and casting, forging, and special equipments. STV equipped with modern valve quality inspection & test center, material chemical composition analysis, mechanical property testing, magnetic particle detection, dye check, X-ray detection, supersonic detection, impact test, flow resistance test, torque test, corrosion test, spectral analysis, metallographic analysis etc test equipments, test equipments such as valve type test machine, life test machine, torque test bench can satisfy various

STV product include Ball, butterfly, check, globe and gate valve obtained nuclear valve design and manufacture license by NNSA. We possessed ISO9001 quality management system, ISO14001 environmental management system, Manufacture



ISO 9001:2008



ISO 14001:2004



OHSAS 18001:2007



API6D



API609



TUV



BV



CE

Technology R&D

The technical advantage of STV includes perfect technology R&D system and personnel. for the purpose of technology continuous innovation, STV has founded its own R&D center which equipped the comprehensive R&D system, like flow resistance test, cryogenic test, fire-safe test, high-temp test, etc. with the development of technical R&D, the advanced design software include ANSYS, JSCAST, Solidworks has been widely applied in STV to ensure the safety of products.

STV introduced great many technical personnel every year to study the prototype design, material and surface treatment technology and have got lots of intellectual property and patent through a series of innovation activities.

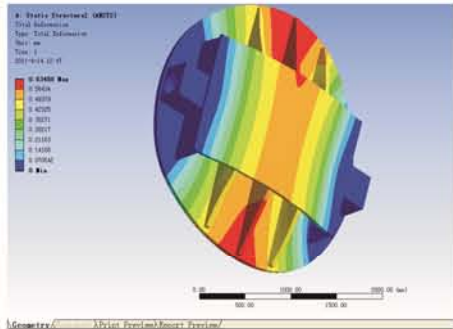

Finite element structural analysis

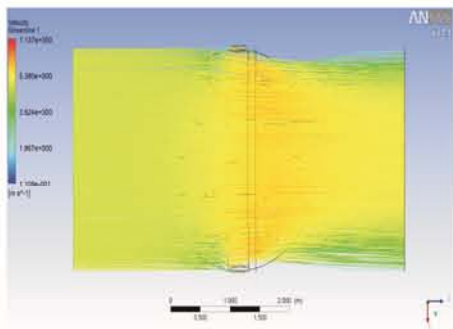

Fluid Analysis



Cryogenic Testing



Flow Resistance Testing



3D Coordinate Instrument

Quality Control

STV has excellent personnel quality management concept and has set up the strict quality system, the complete inspection equipment have been utilized to control the overall process quality from raw material to valve. The inspection includes RT, MT, PT, Spectral Analysis, metallographic Analysis etc. STV's industrial certificates include ISO9001, API6D, API609,

Advanced Manufacturing

The advanced equipment are also widely used in valve manufacture, this include a large number of Vertical Lathe, Horizontal type Lathe, Machining Center, Sphere Grinder, CNC boring and milling machine, DN500 Sphere Grinder etc. All the product process is control by the ERP system to ensure the both of quality and delivery.



Horizontal type Lathe



Machining Center



Ball Valve Assembling workshop



DN500 Sphere Grinder



CNC boring and milling machine



Butterfly Valve Assembling workshop

Optional Material

Body Material

Material	A105	LF2	F316	F304	F316L	F304L	Alloy20	F51
ASTM	A105N	A350 LF2	A182 F316	A182F304	A182F316L	A182F304L	Alloy20	A182F51
Material	WCB	LCB	CF8M	CF8	CF3M	CF3	CN7M	4A
ASTM	A216 WCB	A352 LCB	A351CF8M	A351 CF8	A351CF3M	A351 CF3	A351 CN7M	A890 4A

Trim

Seat	Gasket	Stem	Ball	Packing
PTFE	NBR	AISI 410	AISI 410	PTFE
NYLON1010	VITON	F304	F304	Graphite
PEEK	VITON AED	A105/ENP	A105/ENP	
NYLON 12	VITON B	17-4PH	17-4PH	
PCTFE	HNBR-70	AISI 4140/ENP	AISI 4140/ENP	
FILLED PTFE	VITON GLT	F316	F316	
TFM1700	BUNAN	F51	F51	

Note: Other material if applicable can be supplied as per customers request.

RB, 1-PC, SIDE ENTRY DESIGN

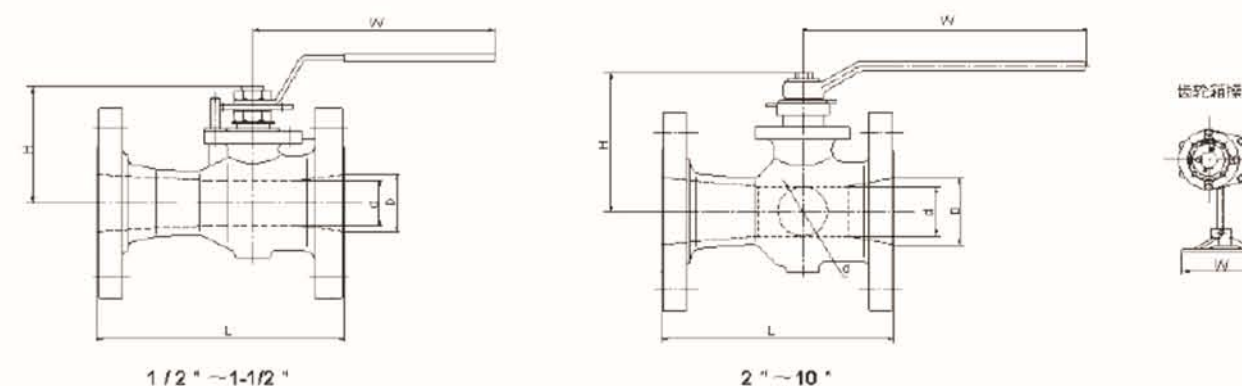

Class 150

口径		d		D		L		H		W		Weight	
in	mm	in	mm	in	mm	in	mm	in	mm	in	mm	lb	kg
1/2	15	0.37	10	0.5	13	4.25	108	2.13	54	4.72	120	33	1.5
3/4	20	0.5	13	0.75	19	4.61	117	2.32	59	5.51	140	55	2.5
1	25	0.75	19	1	25	5	127	2.52	64	5.51	140	66	3
1-1/2	40	1.18	30	1.5	38	6.5	165	3.54	90	6.3	160	11	5
2	50	1.5	38	2	51	7.01	178	4.02	102	10.43	265	192	8.7
2-1/2	65	2	51	2.5	64	7.52	191	4.41	112	10.43	265	27.3	12.4
3	80	2.5	64	3	75	7.99	203	4.76	121	10.43	265	36.8	15.7
4	100	3	75	4	102	9.02	229	6.54	165	11.81	300	53.8	24.4
6	150	4.5	114	6	152	10.51	267	8.19	208	15.75	400	110.2	50
8	200	6	152	8	203	11.5	292	9.69	246	11.81	*300	222.7	101
10	250	7.36	187	10	254	12.99	330	11.93	303	16	*400	330.7	150

Class 300

口径		d		D		L		H		W		Weight	
in	mm	in	mm	in	mm	in	mm	in	mm	in	mm	lb	kg
1/2	15	0.37	10	0.5	13	5.51	140	2.13	54	4.72	120	6.2	2.8
3/4	20	0.5	13	0.75	19	5.98	152	2.32	59	5.51	140	7.9	3.6
1	25	0.75	19	1	25	6.5	165	2.52	64	5.51	140	10.6	4.8
1-1/2	40	1.18	30	1.5	38	7.48	190	3.54	90	6.3	160	21.2	9.6
2	50	1.5	38	2	51	8.5	216	4.02	102	10.43	265	24.3	11.0
2-1/2	65	2	51	2.5	64	9.49	241	4.41	112	10.43	265	33.3	15.1
3	80	2.5	64	3	75	11.14	283	4.76	121	10.43	265	49.6	22.5
4	100	3	75	4	102	12.01	305	6.54	165	11.81	300	81.6	37
6	150	4.5	114	6	152	15.87	403	8.19	208	11.81	*300	159.8	72.5
8	200	6	152	8	203	16.5	419	9.69	246	15.75	*400	275.6	125
10	250	7.36	187	10	254	17.99	457	11.93	303	15.75	*400	451.9	205

*Gear operation

2-Pcs, SPLIT BODY, SIDE ENTRY, CAST STEEL DESIGN

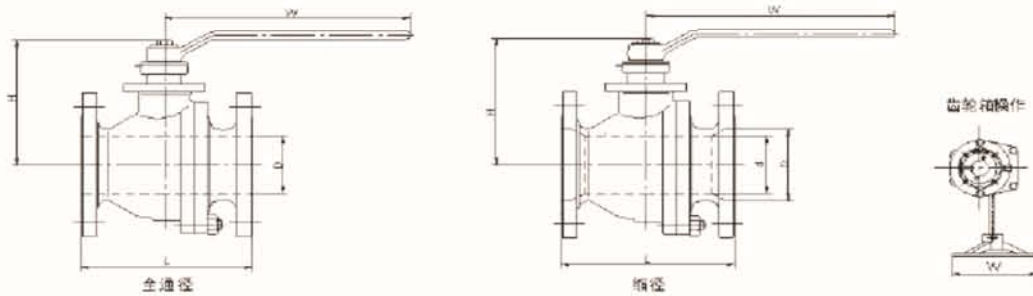

Class 150

Full Port											
Size		D		L		H		W		Weight	
in	mm	in	mm	in	mm	in	mm	in	mm	lb	kg
1/2	15	0.5	13	4.25	108	2.32	59	5.12	130	4	1.8
3/4	20	0.75	19	4.61	117	2.48	63	5.12	130	4.4	2.0
1	25	1	25	5	127	2.99	76	6.3	160	7.9	3.6
1-1/2	40	1.5	38	6.5	165	3.82	97	9.06	230	15.9	7.2
2	50	2	51	7.01	178	4.21	107	9.06	230	24.5	11.1
2-1/2	65	2.5	64	7.48	190	5.59	142	15.75	400	30.9	14
3	80	3	76	7.99	203	5.98	152	15.75	400	48.5	22
4	100	4	102	9.02	229	7.01	178	27.56	700	116.8	53
5	125	5	127	14.02	356	9.92	252	43.31	1100	127.9	58
6	150	6	152	15.51	394	10.71	272	11.81	*300	238.1	108
8	200	7.99	203	17.99	457	13.46	342	11.81	*300	429.9	195
10	250	10	254	12.98	533	13.58	345	15.75	*400	687.8	312
12	300	12	305	24.02	610	18.86	479	23.62	*600	762.8	346

Reduced Port													
Size		d		D		L		H		W		Weight	
in	mm	in	mm	in	mm	in	mm	in	mm	in	mm	lb	kg
3/4*1/2	20*15	0.5	13	0.75	19	4.63	118	3.23	82	5.12	130	6.6	3
1*3/4	25*20	0.75	19	1	25	5	127	3.35	85	5.12	130	9.9	4.5
1-1/2*1	40*25	1	25	1.5	38	6.5	165	3.94	100	6.3	160	15.4	7
2*1-1/2	50*40	1.5	38	2	51	7.01	178	4.53	115	9.06	230	19.8	9
2-1/2*2	65*50	2	51	2.5	64	7.48	190	4.72	120	9.06	230	33.1	15
3*2	80*50	2	51	3	76	7.99	203	6.02	153	15.75	400	35.3	16
4*3	100*80	3	76	4	102	9.02	229	6.38	162	15.75	400	65	29.5
6*4	150*100	4	102	6	152	15.51	394	7.52	191	18.11	460	105.8	48
8*6	200*150	6	152	8	203	17.99	457	11.42	290	11.81	*300	271.2	123
10*8	250*200	8	203	10	254	20.99	533	13.39	340	11.81	*300	480.6	218
12*10	300*250	10	254	12	305	24.02	610	17.4	442	15.75	*400	507.1	230

*Gear operation

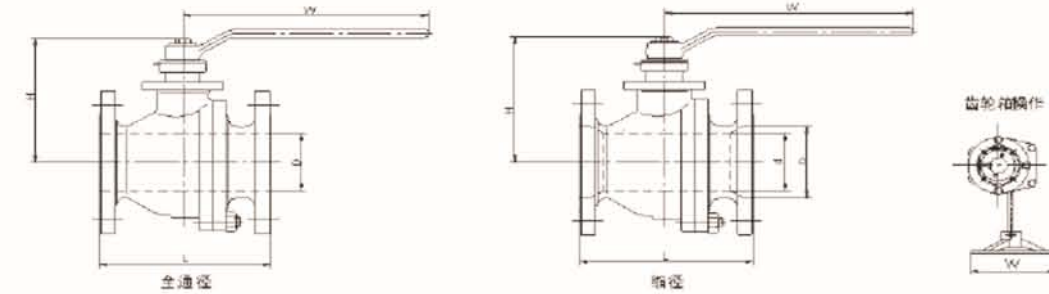

Class 300

Full Port											
Size		D		L		H		W		Weight	
in	mm	in	mm	in	mm	in	mm	in	mm	lb	kg
1/2	15	0.5	13	5.51	140	2.32	59	5.12	130	5.1	2.3
3/4	20	0.75	19	5.98	152	2.48	63	5.12	130	7.9	3.6
1	25	1	25	6.5	165	2.95	75	6.3	160	11.2	5.1
1-1/2	40	1.5	38	7.48	190	3.82	97	9.06	230	22	10
2	50	2	51	8.5	216	4.21	107	9.06	230	30.9	14
2-1/2	65	2.5	64	9.49	241	5.59	142	15.75	400	50.7	23
3	80	3	76	11.14	283	5.98	152	15.75	400	67.5	30.5
4	100	4	102	12.01	305	7.01	178	27.56	700	110.2	50
5	125	5	127	15	381	9.92	252	43.31	1100	205	93
6	150	6	152	15.87	403	10.71	272	11.81	*300	255.7	116
8	200	8	203	19.76	502	13.46	342	11.81	*300	517	234.5
10	250	10	254	22.36	568	13.58	345	15.75	*400	1086.9	493

Reduced Port													
Size		d		D		L		H		W		Weight	
in	mm	in	mm	in	mm	in	mm	in	mm	in	mm	lb	kg
3/4*1/2	20*15	0.5	13	0.75	19	5.98	118	3.23	82	5.12	130	7.7	3.5
1*3/4	25*20	0.75	19	1	25	6.5	127	3.35	85	5.12	130	12.1	5.5
1-1/2*1	40*25	1	25	1.5	38	7.48	165	3.94	100	6.3	160	22	10
2*1-1/2	50*40	1.5	38	2	51	8.5	178	4.53	115	9.06	230	24.3	11
2-1/2*2	65*50	2	51	2.5	64	9.49	190	4.72	120	9.06	230	51.8	23.5
3*2	80*50	2	64	3	76	11.14	203	6.02	153	15.75	400	66.1	30
4*3	100*80	3	76	4	102	12.01	229	6.38	162	15.75	400	86	39
6*4	150*100	4	102	6	152	15.87	394	7.52	191	18.11	460	159.8	72.5
8*6	200*150	6	152	8	203	19.76	457	11.42	290	11.81	*300	326.3	148
10*8	250*200	8	203	10	254	22.36	533	13.39	340	15.75	*300	705.5	320

*Gear operation

2-Pcs, SPLIT BODY, SIDE ENTRY, FORGED STEEL DESIGN

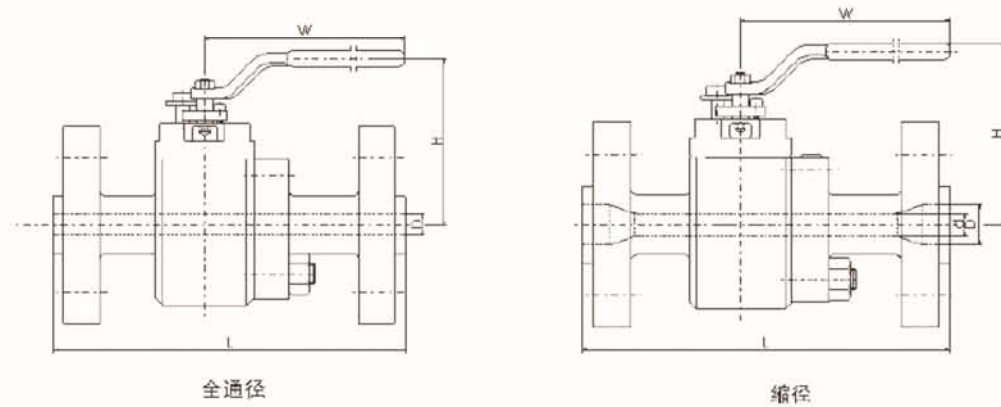

Class 900 LB

Reduced Port													
Size		d		D		L		H		W		Weight	
in	mm	in	mm	in	mm	in	mm	in	mm	in	mm	lb	kg
1/2*3/8	15*10	0.37	9.5	0.5	12.7	8.5	216	3.15	80	4.45	113		
3/4*1/2	20*15	0.5	12.7	0.75	19	9.02	229	4.21	107	5.91	150	22	10
1*3/4	25*20	0.75	19	1	25.4	10	254	5.08	129	7.09	180	33.1	15
1-1/2*1	40*25	1	25.4	1.5	38	12.01	305	5.93	150.5	9.06	230		
2*1-1/2	50*40	1.5	38	2	51	14.49	368	7.72	196	11.81	300	88.2	40

Class 1500 LB

Full Port												
Size		D		L		H		W		Weight		
in	mm	in	mm	in	mm	in	mm	in	mm	lb	kg	
1/2"	15	0.5	12.7	8.5	216	4.21	107	5.91	150	15	6.8	
3/4"	20	0.75	19	9.02	229	5.08	129	7.09	180	24.3	11	
1"	25	1	25.4	10	254	5.93	150.5	9.06	230	35.3	16	
1-1/2"	40	1.5	38	12.01	305	7.72	196	11.81	300	71.9	32.6	
2"	50	2	51	14.49	368	9	228.5	14.57	370	141.1	64	

Reduced Port													
Size		d		D		L		H		W		Weight	
in	mm	in	mm	in	mm	in	mm	in	mm	in	mm	lb	kg
1/2*3/8	15*10	0.37	9.5	0.5	12.7	8.5	216	3.15	80	4.45	113		
3/4*1/2	20*15	0.5	12.7	0.75	19	9.02	229	4.21	107	5.91	150	22	10
1*3/4	25*20	0.75	19	1	25.4	10	254	5.08	129	7.09	180	33.1	15
1-1/2*1	40*25	1	25.4	1.5	38	12.01	305	5.93	150.5	9.06	230	61.7	28
2*1-1/2	50*40	1.5	38	2	51	14.49	368	7.72	196	11.81	300	90.4	41

3-Pcs, SPLIT BODY, SIDE ENTRY, FORGED STEEL DESIGN

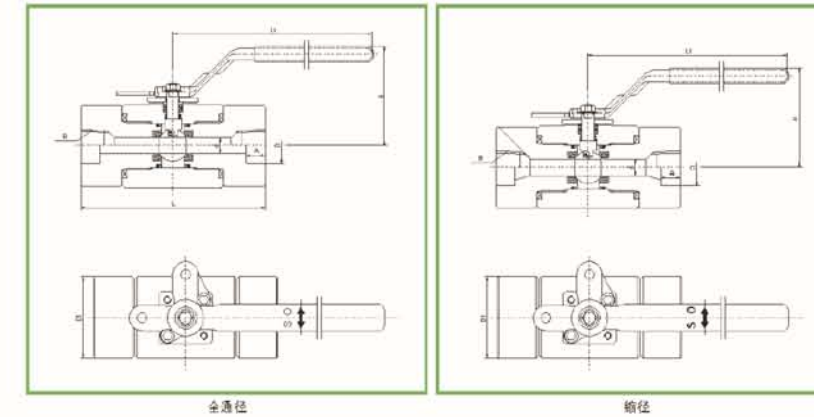

Class 800/ 1500/ 2500 LB

Full Port																			
Size		D		L		H		L1		A		D		D1		B		Weight	
in	mm	in	mm	in	mm	in	mm	in	mm	in	mm	in	mm	in	mm	in	mm	lb	kg
1/4	8	0.25	6.4	0.25	76	2.99	41	1.6	100	3.94	9.5	0.37	14.2	0.56	33	1/4-18NPT	0.6	1.4	
3/8	10	0.38	10	0.37	84	3.31	45	1.76	120	4.72	9.5	0.37	17.6	0.69	38	3/8-18NPT	0.9	1.9	
1/2"	15	0.5	13	0.51	107	4.09	62	2.44	150	5.91	9.5	0.37	21.9	0.86	42	1/2-14NPT	1.2	2.7	
3/4"	20	0.75	20	0.79	127	5	82	3.23	180	7.09	12.5	0.49	27.2	1.07	58	3/4-14NPT	2.9	6.3	
1"	25	1	25	0.98	157	6.18	100	3.94	230	9.06	12.5	0.49	33.9	1.33	72	1-11.5NPT	5.4	12	
1-1/2"	40	1.5	38	1.5	197	7.76	135	5.31	300	11.81	12.5	0.49	40	1.92	105	1/2-11.5NPT	14.3	31.6	
2"	50	2	51	2.01	210	8.27	165	5.5	370	14.57	16	0.63	51.2	2.41	134	2-11.5NPT	24.5	54.1	

Reduced Port																			
Size		D		L		H		L1		A		D		D1		B		Weight	
in	mm	in	mm	in	mm	in	mm	in	mm	in	mm	in	mm	in	mm	in	mm	lb	kg
3/8*1/4	10*8	0.25	6.4	0.25	76	2.99	40.6	1.6	100	3.94	9.5	0.37	17.6	0.69	33	3/8-18NPT	0.8	1.2	
1/2*3/8	15*10	0.37	9.5	0.37	84	3.31	44.8	1.76	120	4.72	9.5	0.37	11.8	0.86	38	1/2-14NPT	0.8	1.7	
3/4*1/2	20*15	0.51	13	0.51	104	4.09	62	2.44	150	5.91	12.5	0.49	27.2	1.07	42	3/4-14NPT	1.1	2.4	
1*3/4	25*20	0.79	20	0.79	127	5	82	3.23	180	7.09	12.5	0.49	33.9	1.33	58	1-11.5NPT	2.7	5.9	
1-1/2*1	40*25	0.98	25	0.98	157	6.18	100	3.94	230	9.06	12.5	0.49	48.8	1.92	72	1/2-11.5NPT	5.1	11.3	
2*1-1/2	50*40	1.5	38	1.5	197	7.76	135	5.31	300	11.81	16	0.63	61.2	2.41	105	2-11.5NPT	14	30.9	

Flow Coefficient (Cv Value) specification

Size	150LB	300LB	600LB	900LB	1500LB
1/2	25	25	20	16	16
3/4	56	56	48	34	34
1	95	95	64	55	55
1-1/2	308	308	308	165	165
2	500	430	370	320	320
3	1360	1100	1020	920	
4	2500	2000	1850		
6	5300	5250			
8	10750	10100			
10	17500	16820			
12	26750	25950			

Note:

- ① All sizes are in full port.
- ② Pressure Rate as per ASME B16.34 standard.

Pressure Temperature Chart

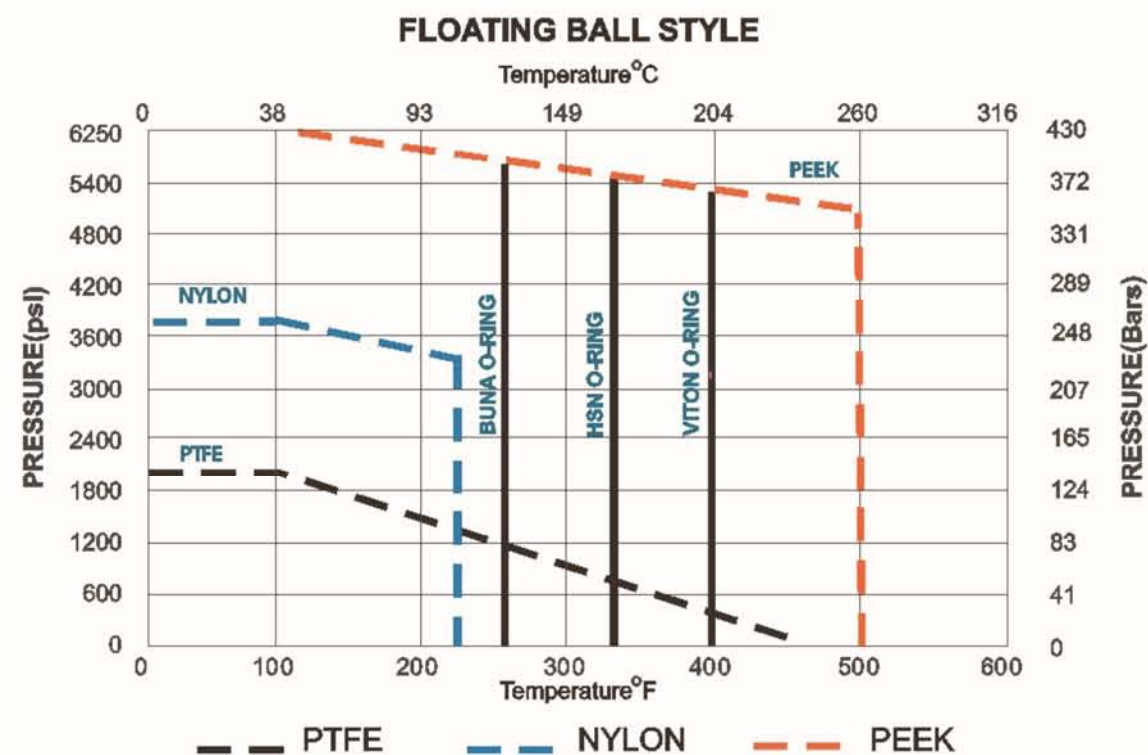

O-Ring materials for floating ball valves are for seat and stem. All Body/bonnet seals are graphite.
 Above ratings are for soft seal components. Please consult ASME B16.34 for Body and Closure Pressure /Temperature ratings.

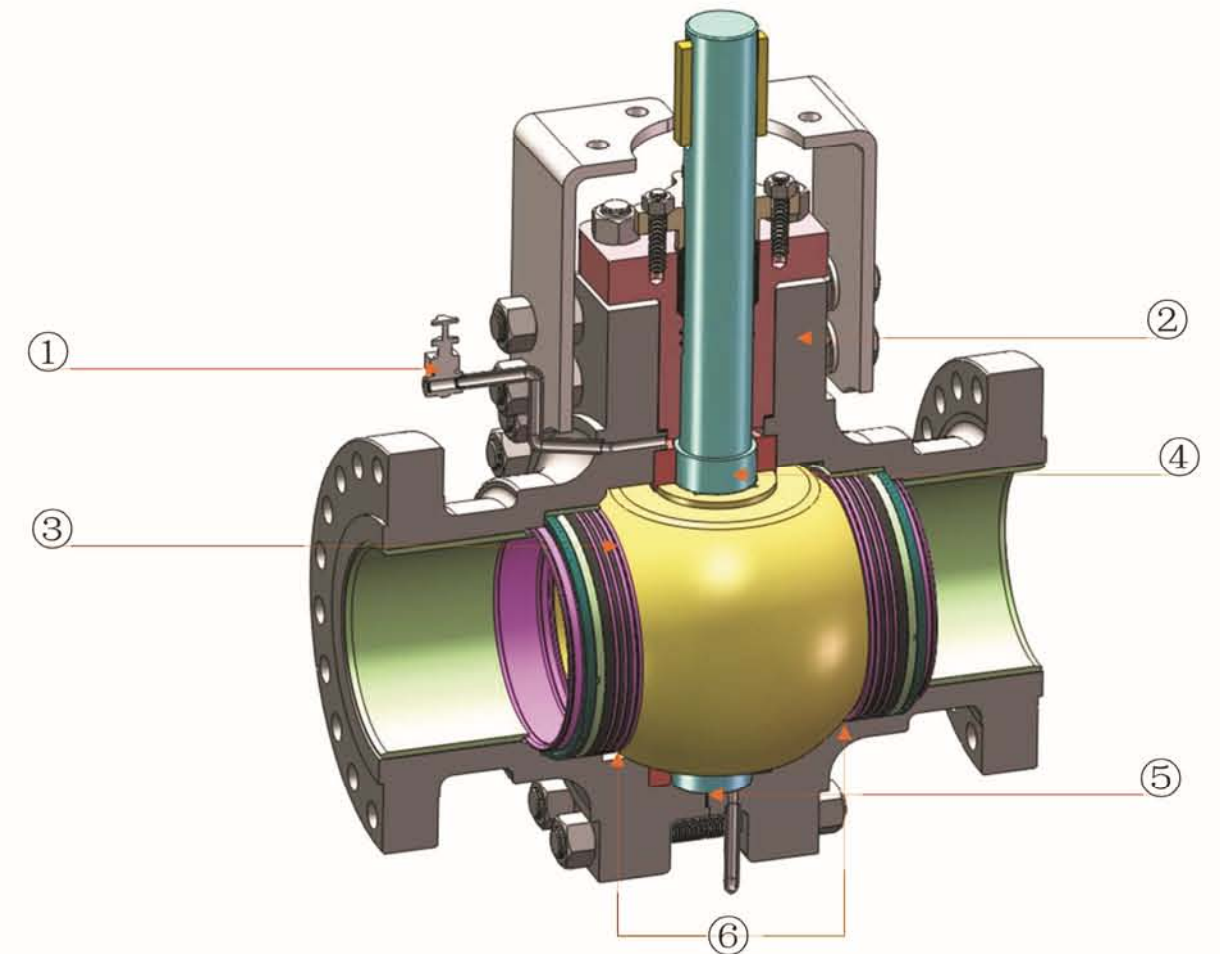

Design Feature

- ① Emergency sealant Injection fitting, prevents leakage form stem and seat.
- ② ISO5211 top mounted flange is selectable.
- ③ Fire safety design.
- ④ Blow-out proof stem, safety feature that functions to assure stem sealing at all pressures.
- ⑤ Anti-static design.
- ⑥ Double block and bleed design.

Technical Specification:

Design: API 6D
 Face to Face dimension: ASME B16.10
 Flange dimension: ASME B16.50
 Test & Inspection: API 598
 Note: Connection flange and Butt-welded end dimension can be designed as per customer's request.

Optional Connection		Optional Operation	
RF	SW	Handle	Bare Shaft
RTJ 法兰	NPT	Gear operator	Hydraulic actuator
FF	SW/ Screwed end	Electric actuator	Gas over oil actuator
BW	55° Taper Screwed end	Pneumatic actuator	Gear (Torque < 350N)

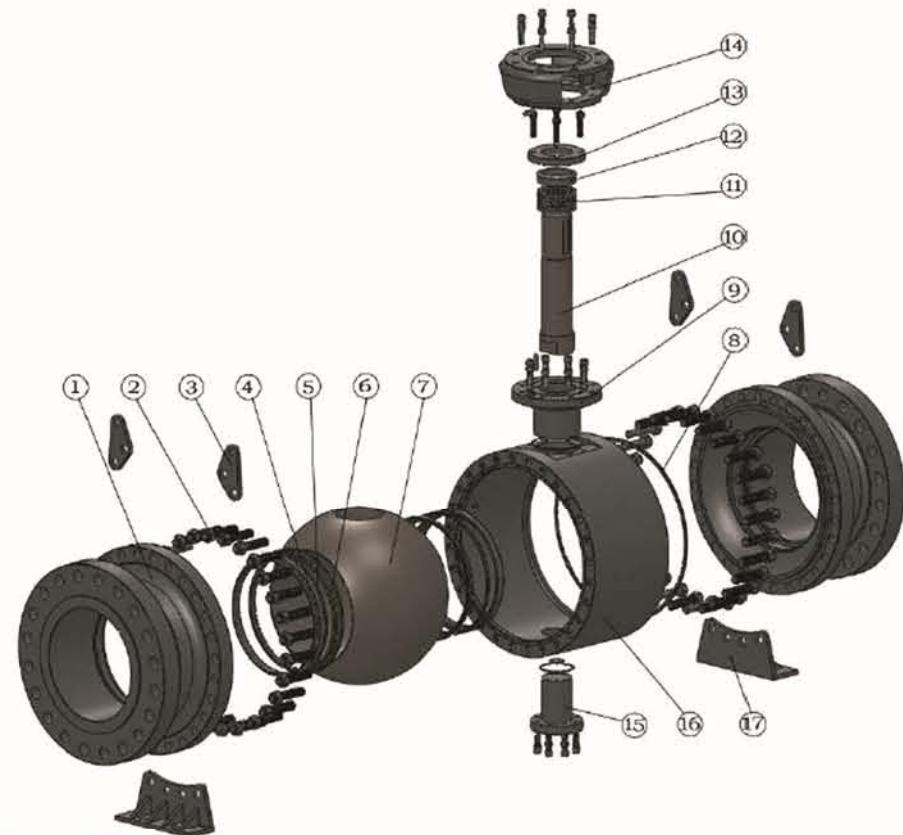

Material Specification

No.	Part	Material			
		Standard	Stainless steel	Sour Service	Cryogenic Service
1	Bonnet	ASTM A216-WCB	ASTM A351-CF8M	ASTM A216-WCB	ASTM A352-LCB
		ASTM A105N	ASTM A182-F316	ASTM A105N	ASTM A350-LF2
2	Gasket	316SS + Graphite	316SS + Graphite	316SS + Graphite	316SS + Graphite
3	Seal ring	RPTFE/NYLON/PEEK	RPTFE/NYLON/PEEK	RPTFE/NYLON/PEEK	RPTFE/NYLON/PEEK
4	Disc spring	Carbon steel	Stainless steel	Carbon steel	Stainless steel
5	Seat	RPTFE/NYLON/PEEK	RPTFE/NYLON/PEEK	RPTFE/NYLON/PEEK	RPTFE/NYLON/PEEK
6	Gasket	316SS + Graphite	316SS + Graphite	316SS + Graphite	316SS + Graphite
7	Ball	ASTM A105N+ENP	ASTM A182-F316	ASTM A105N+ENP	ASTM A350-LF2/ENP
8	Body	ASTM A216-WCB	ASTM A351-CF8M	ASTM A216-WCB	ASTM A352-LCB
		ASTM A105N	ASTM A182-F316	ASTM A105N	ASTM A182-F316
9	Stem	ASTM A105N+ENP	ASTM A182-F316	ASTM A105N+ENP	ASTM A350-LF2/ENP
10	Thrust washer	25%GL+TFE	25%GL+TFE	25%GL+TFE	25%GL+TFE
11	Bushing	ASTM A105N+ENP	ASTM A182-F316	ASTM A105N+ENP	ASTM A350-LF2/ENP
12	Packing	Graphite	Graphite	Graphite	Graphite
13	Packing bushing	ASTM A105N	ASTM A182-F316	ASTM A105N	ASTM A350-LF2
14	Packing gland	ASTM A105N	ASTM A182-F316	ASTM A105N	ASTM A350-LF2
15	Below Shaft	316+PTFE+MoS2	316+PTFE+MoS2	316+PTFE+MoS2	316+PTFE+MoS2

Optional Material

Body Material

Material	Casting marks	Forging marks	Temperature range	
			°C	°F
Carbon steel	A216 Grade WCB	A105N	-29~425	-20~800
Carbon	A352 Grade LCB	A350 Grade LF2	-46~350	-50~650
Carbon	A352 Grade LCC	A350 Grade LF2	-46~350	-50~650
Duplex steel	A995 Grade 4A	A182 Grade F51	-51~315	-60~599
Duplex steel	A995 Grade 5A	A182 Grade F53	-51~315	-60~599
Austenitic stainless steel	A354 Grade CF8M	A182 Grade F316	-196~815	-320~1500
Austenitic stainless steel	A351 Grade CF8	A182 Grade F304	-196~815	-320~1500
LC Austenitic	A351 Grade CF3M	A182 Grade F316L	-196~815	-320~1500
LC Austenitic	A351 Grade CF3	A182 Grade F304L	-196~815	-320~1500
Ni Alloy steel	A351 Grade CN7M	Alloy 20	-196~425	-320~800

Trim

Seal ring	O-ring	Stem	Ball	Seat
RPTFE	NBR	F6a	F6a	F6a
NYLON 1010	VITON A	F304	F304	F304
PEEK	VITON AED	A105N/ENP	A105N/ENP	A105N/ENP
Polyphenylene	VITON B	17-4PH	17-4PH	17-4PH
DEVELON V	HSN	AISI 4140	AISI 4140	AISI 4140
KEL-F	HNBR	F316	F316	F316
NYLON 12	PTFE COATED DVELON	F304L	F304L	F304L
PCTFE	VITON GLT	F316L	F316L	F316L
MOLON	BUNA-A	LF2/BNP	LF2/BNP	LF2/BNP
PVDF	ELAST-O-UON 101	F51	F51	F51
	EPDM			

Note: Other material is upon reqy=uest.

2-Pcs, SPLIT BODY, SIDE ENTRY, CAST STEEL DESIGN

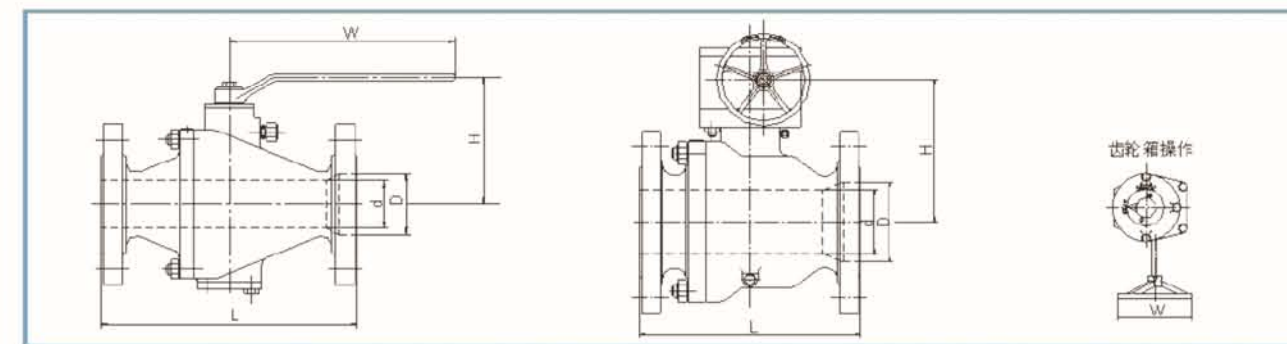
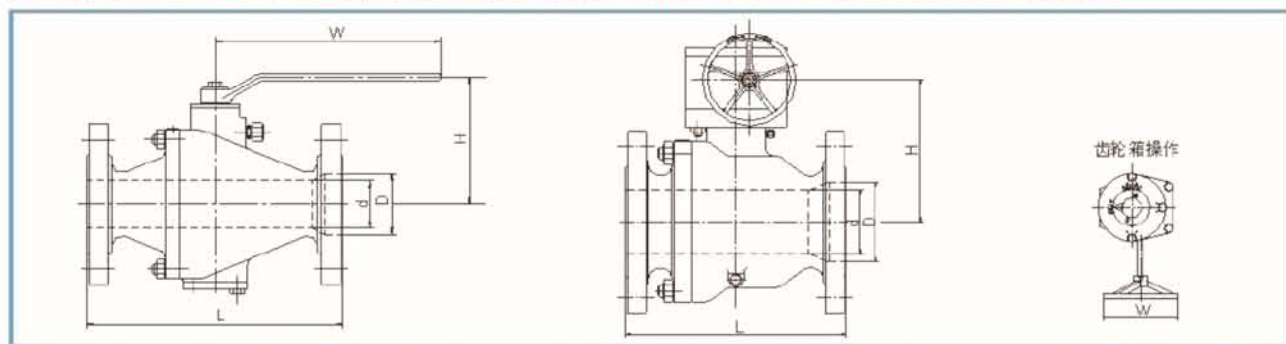

Class 150

Full Port											
Size		d		L		H		W		Weight	
in	mm	in	mm	in	mm	in	mm	in	mm	lb	kg
2	50	2.01	51	7.01	178	6.5	165	9.06	230	37.5	17
3	80	2.99	76	7.99	203	7.6	193	15.75	400	72.8	33
4	100	4.02	102	9.02	229	9.09	231	18.11	460	110.2	50
6	150	5.98	152	15.51	394	12.95	329	39.37	1000	205	93
8	200	7.99	203	17.99	457	15.47	393	19.69	*500	366	166
10	250	10	254	20.98	533	15.79	401	19.69	*500	601.9	273
12	300	12.01	305	24.02	610	17.36	441	19.69	*500	1047.2	475
14	350	13.27	337	27.01	686	18.94	481	19.69	*500	1256.6	570
16	400	15.24	387	30	762	23.54	598	19.69	*500	1715.2	778
18	450	17.24	438	34.02	864	25.31	643	19.69	*500	2061.3	935
20	500	19.25	489	35.98	914	27.87	708	19.69	*500	2623.5	1190
22	550	21.26	540	40	1016	31.42	798	19.69	*500	2967.4	1346
24	600	23.27	591	42.01	1067	33.98	863	19.69	*500	3481	1579

Reduced Port													
Size		d		D		L		H		W		Weight	
in	mm	in	mm	in	mm	in	mm	in	mm	in	mm	lb	kg
3*2	80*50	2.01	51	2.99	76	7.99	203	6.5	165	9.06	230	66.1	30
4*3	100*80	2.99	76	4.02	102	9.02	229	7.6	193	15.75	400	103.6	47
6*4	150*100	4.02	102	5.98	152	15.51	394	9.09	231	15.75	400	198.4	90
8*6	200*150	5.98	152	7.99	203	17.99	457	12.95	329	18.11	460	354.9	161
10*8	250*200	7.99	203	10	254	20.98	533	15.47	393	39.37	1000	590.8	268
12*10	300*250	10	254	12.01	305	24.02	610	15.47	393	19.69	*500	1029.5	467
14*12	350*300	12.01	305	13.27	337	27.01	686	17.36	441	19.69	*500	1234.6	560
16*14	400*350	13.27	337	15.24	387	30	762	18.94	481	19.69	*500	1688.7	766
18*16	450*400	15.24	387	17.24	438	34.02	864	23.54	598	19.69	*500	1988.5	902
20*18	500*450	17.24	438	19.25	489	35.98	914	25.31	643	19.69	*500	2491.2	1130
22*20	550*500	19.25	489	21.26	540	40	1016	25.31	643	19.69	*500	2866	1300
24*20	600*550	19.25	489	23.27	591	42.01	1067	27.87	708	19.69	*500	3351	1520

* Gear operation

Class 300

Full Port											
Size		d		L		H		W		Weight	
in	mm	in	mm	in	mm	in	mm	in	mm	lb	kg
2	50	2.01	51	8.5	216	6.5	165	9.06	230	397	18
3	80	2.99	76	11.14	283	7.6	193	15.75	400	882	40
4	100	4.02	102	12.01	305	9.09	231	18.11	460	138.9	63
6	150	5.98	152	15.87	403	12.95	329	39.37	1000	330.7	150
8	200	7.99	203	19.76	502	15.47	393	59.06	1500	529.1	240
10	250	10	254	22.36	568	15.79	401	19.69	*500	672.4	305
12	300	12.01	305	22.51	648	17.36	441	19.69	*500	1117.7	507
14	350	13.27	337	30	762	18.94	481	19.69	*500	1327.2	602
16	400	15.24	387	32.99	838	23.54	598	19.69	*500	2204.6	1000
18	450	17.24	438	35.98	914	25.31	643	19.69	*500	2557.3	1160
20	500	19.25	489	39.02	991	27.87	708	19.69	*500	2910.1	1320
22	550	21.26	540	42.99	1092	31.42	798	19.69	*500	3395.1	1540
24	600	23.27	591	45	1143	33.98	863	19.69	*500	4131.4	1874

Reduced Port													
Size		d		D		L		H		W		Weight	
in	mm	in	mm	in	mm	in	mm	in	mm	in	mm	lb	kg
3*2	80*50	2.01	51	2.99	76	11.14	283	6.5	165	9.06	230	83.8	38
4*3	100*80	2.99	76	4.02	102	12.01	305	7.6	193	15.75	400	132.3	60
6*4	150*100	4.02	102	5.98	152	15.87	403	9.09	29.53	750	400	324.1	147
8*6	200*150	5.98	152	7.99	203	19.76	502	12.95	329	39.37	1000	515.9	234
10*8	250*200	7.99	203	10	254	22.36	568	15.47	393	59.06	1500	650.4	295
12*10	300*250	10	254	12.01	305	25.51	648	15.47	393	19.69	*500	1075.8	488
14*12	350*300	12.01	305	13.27	337	30	762	17.36	441	19.69	*500	1256.6	570
16*14	400*350	13.27	337	15.24	387	32.99	838	18.94	481	19.69	*500	2006.2	910
18*16	450*400	15.24	387	17.24	438	35.98	914	23.54	598	19.69	*500	2248.7	1020
20*18	500*450	17.24	438	19.25	489	39.02	991	25.31	643	19.69	*500	2821.0	1280
22*20	550*500	19.25	489	21.26	540	42.99	1092	25.31	643	19.69	*500	2998.2	2360
24*20	600*550	19.25	489	23.27	591	45	1143	27.87	708	19.69	*500	3681.7	1670

* Gear operation

2-Pcs, SPLIT BODY, SIDE ENTRY, CAST STEEL DESIGN

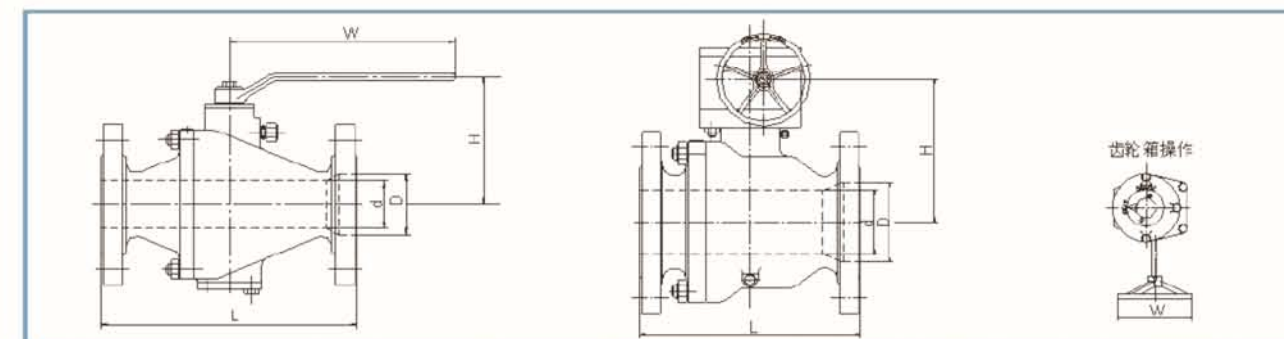
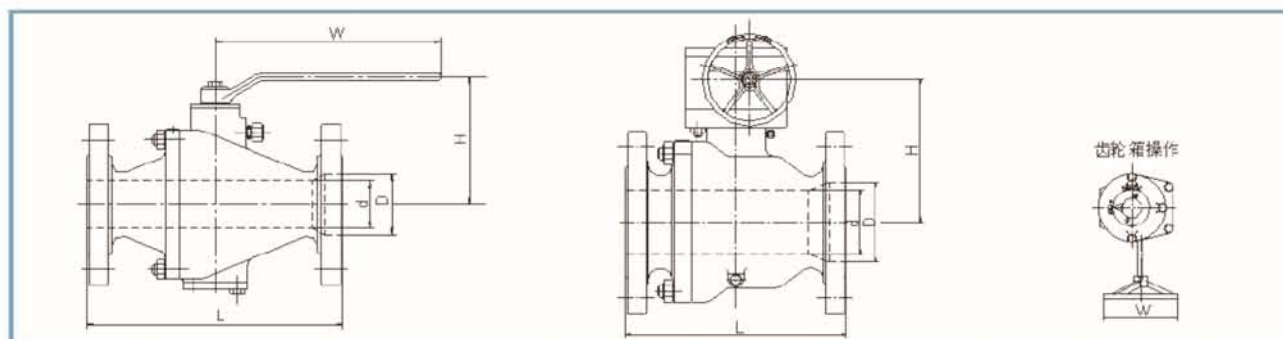

Class 600

Full Port											
Size		d		L		H		W		Weight	
in	mm	in	mm	in	mm	in	mm	in	mm	lb	kg
2	50	2.01	51	11.5	292	6.93	176	1575	400	59.5	27
3	80	2.99	76	14.02	356	9.72	247	2953	750	110.2	50
4	100	4.02	102	17.01	432	10.87	276	3937	1000	176.4	80
6	150	5.98	152	22.01	559	14.29	363	5906	1500	775.6	351
8	200	7.99	203	25.98	660	14.29	363	19.69	*500	771.6	350
10	250	10	254	30.98	787	16.77	426	19.69	*500	1322.8	600
12	300	12.01	305	32.99	838	21.57	549	19.69	*500	1807.8	820
14	350	13.27	337	35	889	23.54	598	19.69	*500	2491.2	1130
16	400	15.24	387	39.02	991	25.51	648	19.69	*500	3417.1	1550
18	450	17.24	438	42.99	1092	29.13	740	19.69	*500	4629.6	2100
20	500	19.25	489	47.01	1194	31.89	810	19.69	*500	6172.8	2800
24	600	23.27	591	55	1397	36.22	920	19.69	*500	7993.8	7626

Reduced Port													
Size		d		D		L		H		W		Weight	
in	mm	in	mm	in	mm	in	mm	in	mm	in	mm	lb	kg
3*2	80*50	2.01	51	2.99	76	14.02	356	6.93	176	15.75	400	90.4	41
4*3	100*80	2.99	76	4.02	102	17.01	432	9.72	247	29.53	750	154.3	70
6*4	150*100	4.02	102	5.98	152	22.01	559	10.87	276	39.37	1000	269	122
8*6	200*150	5.98	152	7.99	203	25.98	660	14.29	363	59.06	1500	562.2	255
10*8	250*200	7.99	203	10	254	30.98	787	14.29	363	19.69	*500	970	440
12*10	300*250	10	254	12.01	305	32.99	838	16.77	426	19.69	*500	1366.8	620
14*12	350*300	12.01	305	13.27	337	35	889	21.57	548	19.69	*500	2336.9	1060
16*14	400*350	13.27	337	15.24	387	39.02	991	23.54	598	19.69	*500	3174.6	1440
18*16	450*400	15.24	387	17.24	438	42.99	1092	25.51	648	19.69	*500	4100.5	1860
20*18	500*450	17.24	438	19.25	489	47.01	1194	29.13	740	19.69	*500	5291	2400
24*20	600*550	19.25	489	23.27	591	55	1397	31.89	810	19.69	*500	7142.9	3240

* Gear operation

Class 900

Full Port											
Size		d		L		H		W		Weight	
in	mm	in	mm	in	mm	in	mm	in	mm	lb	kg
2	50	2.01	51	14.49	368	7.56	192	18.11	460	114.6	52
3	80	2.99	76	15	381	9.8	249	39.37	1000	213.8	97
4	100	4.02	102	17.99	457	12.4	315	59.06	1500	304.2	138
6	150	5.98	152	24.02	610	12.72	323	19.69	*500	634.9	288
8	200	7.99	203	29.02	737	15	381	19.69	*500	987.7	448
10	250	10	254	32.99	838	20.39	518	19.69	*500	1649	748
12	300	12.01	305	37.99	965	22.36	568	19.69	*500	2244.3	1018
14	350	12.76	324	40.51	1029	26.18	665	19.69	*500	3082	1398
16	400	14.76	375	44.49	1130	28.74	730	19.69	*500	4030	1828
18	450	16.73	425	47.99	1219	31.3	795	19.69	*500	5132.3	2328
20	500	18.62	473	53.01	1321	32.48	825	24.02	*610	6455	2928
24	600	22.52	572	60.98	1549	38.31	973	24.02	*610	9210.8	4178

Reduced Port													
Size		d		D		L		H		W		Weight	
in	mm	in	mm	in	mm	in	mm	in	mm	in	mm	lb	kg
3*2	80*50	2.01	51	2.99	76	15	381	7.56	192	18.11	460	183	83
4*3	100*80	2.99	76	4.02	102	17.99	457	9.8	249	39.37	1000	227.1	103
6*4	150*100	4.02	102	5.98	152	24.02	610	12.4	315	59.06	1500	443.1	201
8*6	200*150	5.98	152	7.99	203	29.02	737	12.72	323	19.69	*500	767.2	348
10*8	250*200	7.99	203	10	254	32.99	838	15	381	19.69	*500	1318.3	598
12*10	300*250	10	254	12.01	305	37.99	965	20.39	518	19.69	*500	1737.2	788
14*12	350*300	12.01	305	12.76	324	40.51	1029	22.36	568	19.69	*500	2425	1100
16*14	400*350	12.76	324	14.76	375	44.49	1130	26.18	665	19.69	*500	3130.5	1420
18*16	450*400	14.76	375	16.73	425	47.99	1219	28.74	730	19.69	*500	4250.4	1928
20*18	500*450	16.73	425	18.62	473	52.01	1321	31.3	795	19.69	*500	5352.7	2428
24*20	600*550	18.62	473	22.52	572	60.98	1549	32.48	825	24.02	*610	7888	3578

* Gear operation

2-Pcs, SPLIT BODY, SIDE ENTRY, CAST STEEL DESIGN

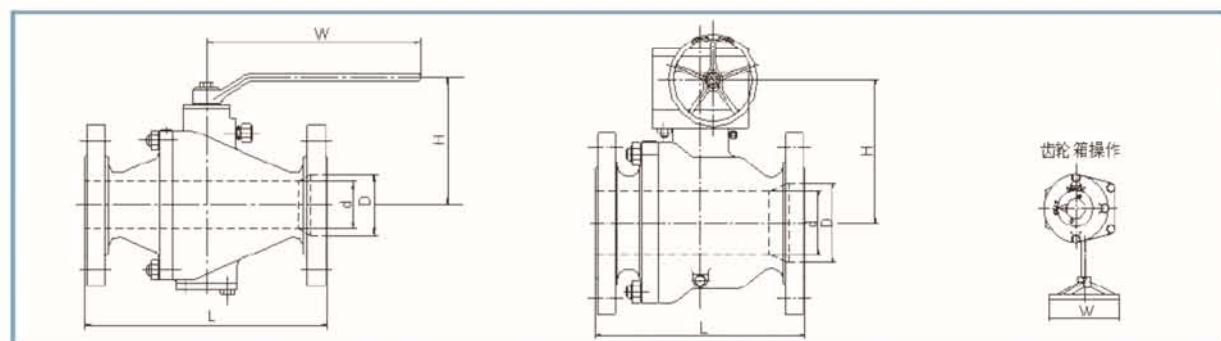

3-Pcs, SPLIT BODY, SIDE ENTRY, FORGED STEEL DESIGN

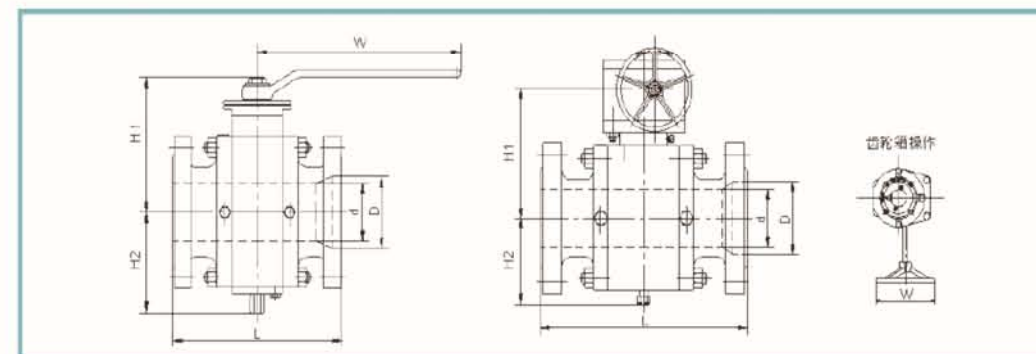

Class 1500 LB

Full Port											
Size		d		L		H		W		Weight	
in	mm	in	mm	in	mm	in	mm	in	mm	lb	kg
2	50	2.01	51	14.49	368	9.92	252	29.53	750	189.6	86
3	80	2.99	76	18.5	470	11.81	300	59.06	1500	299.8	136
4	100	4.02	102	21.5	546	10.71	272	19.69	*500	487.2	221
6	150	5.75	145	27.76	705	13.43	341	19.69	*500	855.4	388
8	200	7.64	194	32.76	832	19.41	493	19.69	*500	1278.7	580
10	250	9.49	241	39.02	991	22.24	565	19.69	*500	2089.9	948
12	300	11.38	289	44.49	1130	27.56	700	19.69	*500	2949.7	1338
14	350	12.52	318	49.49	1257	29.41	747	19.69	*500	3853.6	1748
16	400	14.25	362	54.49	1384	31.3	795	24.02	*610	4911.8	2228
18	450	16.02	407	60.51	1537	34.53	877	24.02	*610	6283.1	2850
20	500	17.99	457	65.51	1664	38.78	985	24.02	*610	10714.3	4860

Class 150 LB

Full Port													
Size		D		L		H1		H2		W		Weight	
in	mm	in	mm	in	mm	in	mm	in	mm	in	mm	lb	kg
2	50	2.01	51	7.01	178	7.87	200	4.33	110	10.43	265	46.3	21
3	80	2.99	76	7.99	203	11.81	300	4.96	126	11.22	285	70.6	32
4	100	4.02	102	9.02	229	12.4	315	6.5	165	11.22	285	110.2	50
6	150	5.98	152	15.51	394	13.19	335	6.5	165	11.81	300	361.6	164
8	200	7.99	203	17.99	457	15.94	405	7.87	200	11.81	300	760.6	345
10	250	10	254	20.98	533	16.81	427	8.66	220	11.81	300	970	440
12	300	12.01	305	24.02	610	18.31	465	10.31	262	19.69	*500	1272.1	577
14	350	13.27	337	27.01	686	19.92	506	11.54	293	23.62	*600	1893.7	859
16	400	15.24	387	30	762	24.49	622	13.43	341	23.62	*600	2522.1	1144
18	450	17.24	438	34.02	864	26.22	666	16.22	412	23.62	*600	3174.6	1440
20	500	19.25	489	35.98	914	28.74	730	17.13	435	23.62	*600	4285.7	1944
22	550	21.26	540	40	1016	32.8	833	18.9	480	23.62	*600	5185.2	2352
24	600	23.27	591	42.01	1067	35.24	895	20.39	518	31.5	*800	6179.5	2803
26	650	25	645	45	1143	35.43	900	21.06	535	31.5	*800	7054.7	3200
28	700	27.01	686	49.02	1245	36.81	935	21.34	542	31.5	*800	8924.2	4048
30	750	29.02	737	50.98	1295	39.76	1010	23.82	605	31.5	*800	13668.4	6200
32	800	30.75	781	54.02	1372	41.73	1060	25.59	650	31.5	*800	12103.2	5490
34	850	32.76	832	57.99	1473	42.4	1077	25.59	650	31.5	*800	14779.5	6704
36	900	34.49	876	60	1524	43.9	1115	27.56	700	31.5	*800	21164	9600
40	1000	38.5	978	67.99	1727	55.12	1400	34.06	865	31.5	*800	22643.3	10271
42	1050	40.24	1022	78.23	1987	62.91	1598	35.43	900	31.5	*800	26697.5	12110
48	1200	45.98	1168	83.46	2120	67.8	1722	41.02	1042	31.5	*800	40476.2	18360

*Gear operation

Reduced Port													
Size		d		D		L		H		W		Weight	
in	mm	in	mm	in	mm	in	mm	in	mm	in	mm	lb	kg
3*2	80*50	2.01	51	2.99	76	18.5	470	9.92	252	29.53	750	216	99
4*3	100*80	2.99	76	4.02	102	21.5	546	11.81	300	59.06	1500	304.2	138
6*4	150*100	4.02	102	5.75	146	27.76	706	10.71	272	19.69	*500	634.9	288
8*6	200*150	5.75	146	7.64	194	32.76	832	13.43	341	19.69	*500	987.7	448
10*8	250*200	7.64	194	9.49	241	39.02	991	19.41	493	19.69	*500	1649	748
12*10	300*250	9.49	241	11.38	289	44.49	1130	22.24	565	19.69	*500	2248.7	1020
14*12	350*300	11.38	289	12.52	318	49.49	1257	27.56	700	19.69	*500	3086.4	1400
16*14	400*350	12.52	318	14.25	362	54.49	1384	29.41	747	19.69	*500	4012.3	1820
18*16	450*400	14.25	362	16.02	407	60.51	1537	31.3	795	24.02	*610	5132.3	2328
20*18	500*450	16.02	407	17.99	457	65.51	1664	34.53	877	24.02	*610	9082.9	4120

* Gear operation

3-Pcs, SPLIT BODY, SIDE ENTRY, FORGED STEEL DESIGN

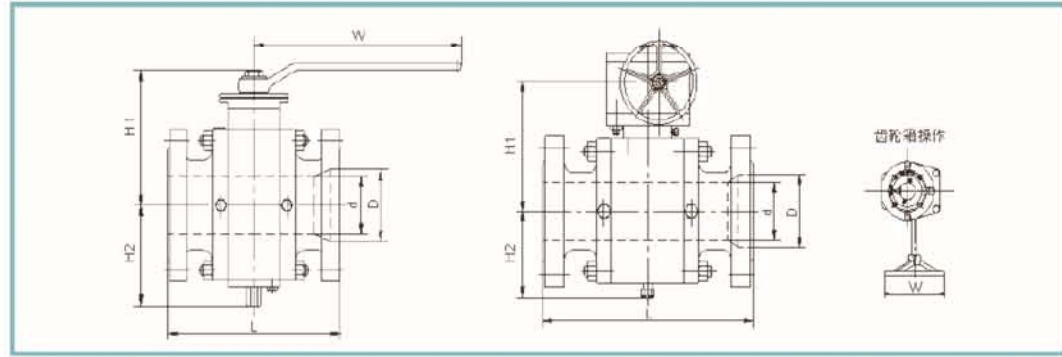

Class 150 LB

Size		d		D		L		H1		H2		W		Weight	
in	mm	in	mm	in	mm	in	mm	in	mm	in	mm	in	mm	lb	kg
3*2	80*50	2.01	51	2.99	76	7.99	203	7.87	200	4.33	110	10.43	265	58.4	27
4*3	100*80	2.99	76	4.02	102	9.02	229	11.81	300	4.96	126	11.22	285	88.2	40
6*4	150*100	4.02	102	5.98	152	15.51	394	12.4	315	6.5	165	11.22	285	149.9	68
8*6	200*150	5.98	152	7.99	203	17.99	457	13.19	335	6.69	170	11.81	*300	390.2	177
10*8	250*200	7.99	203	10	254	21.02	534	15.94	405	7.87	200	11.81	*300	676.8	307
12*10	300*250	10	254	12.01	305	24.02	610	16.81	427	8.66	220	11.81	*300	1122.1	509
14*12	350*300	12.01	305	13.27	337	27.01	686	18.31	465	10.31	262	19.69	*500	1591.7	722
16*14	400*350	13.27	337	15.24	387	30	762	19.92	506	11.54	293	23.62	*600	2138.5	970
18*16	450*400	15.24	387	17.24	438	34.02	864	24.49	622	13.43	341	23.62	*600	2846.1	1291
20*18	500*450	17.24	438	19.25	489	35.98	914	26.22	666	15.43	392	23.62	*600	3681.7	1670
22*20	550*450	19.25	489	21.26	540	39.02	991	26.22	666	15.43	392	23.62	*600	5165.3	2343
24*20	600*500	19.25	489	23.27	591	42.01	1067	28.74	730	17.13	435	23.62	*600	4241.6	1924
26*22	650*550	21.26	540	25	635	45	1143	32.8	833	18.9	480	23.62	*600	4883.2	2215
28*24	700*600	23.27	591	27.01	686	49.02	1245	35.24	895	20.39	518	31.5	*800	5952.4	2700
30*24	750*600	23.27	591	29.02	737	50.98	1295	35.24	895	20.39	518	31.5	*800	6433	2918
32*26	800*650	25	635	30.75	781	54.02	1372	35.43	900	21.06	535	31.5	*800	8829.4	4005
34*28	850*700	27.01	686	32.76	832	57.99	1473	36.81	935	21.34	542	31.5	*800	9799.4	4445
36*30	900*750	29.02	737	34.49	876	60	1524	39.76	1010	23.82	605	31.5	*800	11011.9	4995
40*34	1000*850	32.76	832	38.5	978	67.99	1727	42.4	1077	25.59	650	31.5	*800	18077.6	8200
42*36	1050*900	34.49	876	40.24	1022	78.23	1987	43.9	1115	27.56	700	31.5	*800	23966.1	10871
48*40	1200*1000	38.5	978	45.98	1168	83.46	2120	55.12	1400	34.06	865	31.5	*800	29806	13520

* Gear operation

3-Pcs, SPLIT BODY, SIDE ENTRY, FORGED STEEL DESIGN

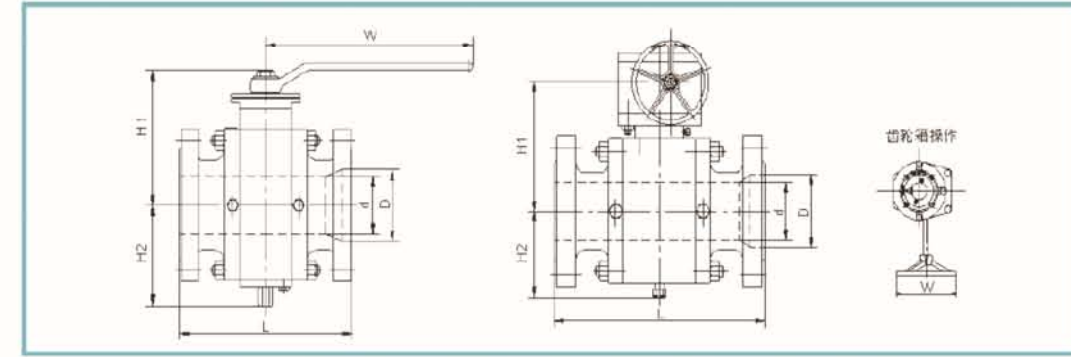

Class 300 LB

Size		D		L		H1		H2		W		Weight	
in	mm	in	mm	in	mm	in	mm	in	mm	in	mm	lb	kg
2	50	2.01	51	8.5	216	8.11	206	4.45	113	10.43	265	55.1	25
3	80	2.99	76	11.14	283	12.4	315	5.08	129	15.75	400	101.4	46
4	100	4.02	102	12.01	305	12.99	330	6.65	169	29.53	750	169.8	77
6	150	5.98	152	15.87	403	13.58	345	5.83	148	11.81	300	377	171
8	200	7.99	203	19.76	502	16.34	415	8.9	226	11.81	300	709.9	322
10	250	10	254	22.36	568	16.81	427	10.59	269	15.75	*400	1190.5	540
12	300	12.01	305	25.51	648	18.31	465	11.81	300	19.69	*500	1682.1	763
14	350	13.27	337	30	762	20.43	519	13.78	350	23.62	*600	2149.5	975
16	400	15.24	387	32.99	838	25.12	638	15.83	402	23.62	*600	3086.4	1400
18	450	17.24	438	35.98	914	26.89	683	17.56	446	23.62	*600	3780.9	1715
20	500	19.25	489	39.02	991	29.45	748	19.37	492	23.62	*600	5465.2	2479
22	550	21.26	540	42.99	1092	33.62	854	20.91	531	23.62	*600	4894.2	2220
24	600	23.27	591	45	1143	36.1	917	21.89	556	31.5	*800	6371.3	2890
28	700	27.01	686	52.99	1346	37.72	958	24.41	620	31.5	*800	10086	4575
30	750	29.02	737	55	1397	40.75	1035	26.22	666	31.5	*800	12323.6	5590
32	800	30.75	781	60	1524	42.8	1087	26.22	666	31.5	*800	13756.6	6240
34	850	32.76	832	64.02	1626	43.46	1104	28.27	718	31.5	*800	16247.8	7370
36	900	34.49	876	67.99	1727	45	1143	27.56	700	31.5	*800	18595.7	8435
40	1000	38.5	978	75.98	1930	56.5	1435	34.92	887	31.5	*800	24691.4	11200
42	1050	40.24	1022	80	2032	64.49	1638	36.34	923	31.5	*800	28769.8	13050
48	1200	45.98	1168	85.43	2170	69.49	1765	42.05	1068	31.5	*800	41887.1	19000

* Gear operation

3-Pcs, SPLIT BODY, SIDE ENTRY, FORGED STEEL DESIGN

3-Pcs, SPLIT BODY, SIDE ENTRY, FORGED STEEL DESIGN

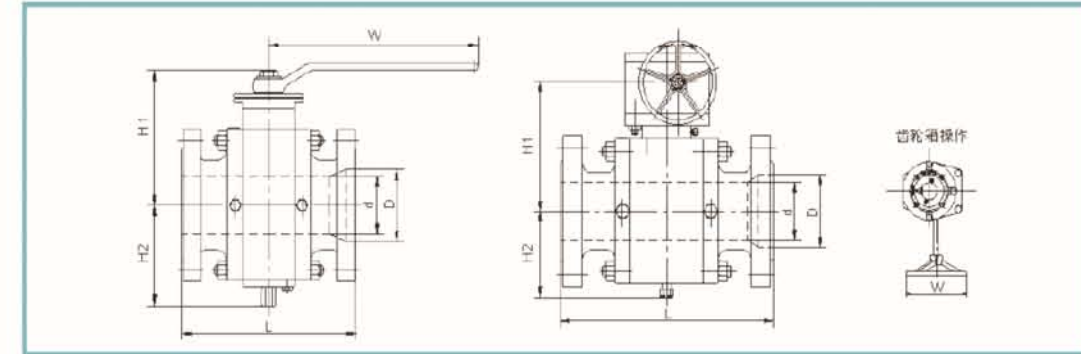
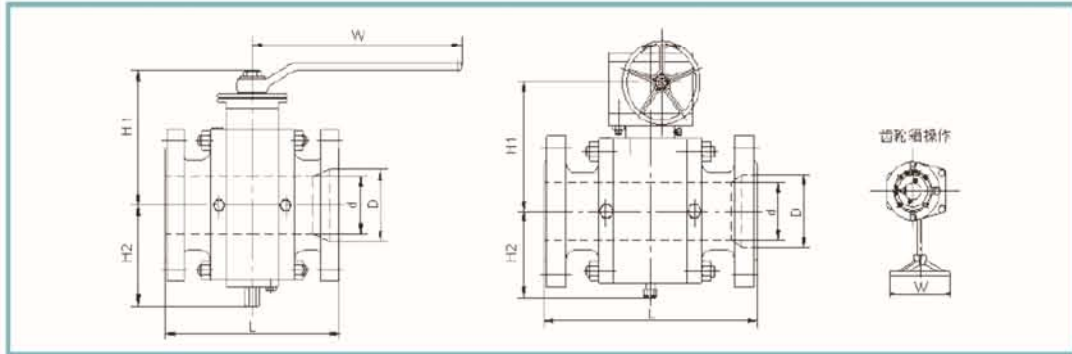

Class 300 LB

Class 600 LB

Reduced Port															
Size		d		D		L		H1		H2		W		Weight	
in	mm	in	mm	in	mm	in	mm	in	mm	in	mm	in	mm	lb	kg
3*2	80*50	2.01	51	2.99	76	11.14	283	8.11	206	4.45	113	10.43	265	79.4	36
4*3	100*80	2.99	76	4.02	102	12.01	305	12.4	315	5.08	129	15.75	400	121.3	55
6*4	150*100	4.02	102	5.98	152	15.87	403	12.99	330	6.65	169	29.53	750	246.9	112
8*6	200*150	5.98	152	7.99	203	19.76	502	13.58	345	5.83	148	11.81	300	489.4	222
10*8	250*200	7.99	203	10	254	22.36	568	16.34	415	7.28	185	11.81	300	839.9	381
12*10	300*250	10	254	12.01	305	25.51	648	16.81	427	8.9	226	15.75	*400	1278.7	580
14*12	350*300	12.01	305	13.27	337	30	762	18.31	465	10.59	269	19.69	*500	2028.2	920
16*14	400*350	13.27	337	15.24	387	32.99	838	20.43	519	11.81	300	23.62	*600	2314.8	1050
18*16	450*400	15.24	387	17.24	438	35.98	914	25.12	638	13.78	350	23.62	*600	3373	1530
20*18	500*450	17.24	438	19.25	489	39.02	991	26.89	683	15.83	402	23.62	*600	4034.4	1830
22*20	550*450	19.25	489	21.26	540	42.99	1092	29.45	748	15.83	402	23.62	*600	4431.2	2010
24*20	600*500	19.25	489	23.27	591	45	1143	33.62	854	17.56	446	23.62	*600	4894.2	2220
28*24	700*600	23.27	591	27.01	686	52.99	1346	36.1	917	20.91	531	31.5	*800	7054.7	3200
30*24	750*600	23.27	591	29.02	737	55	1397	36.1	917	20.91	531	31.5	*800	8708.1	3950
34*28	850*700	27.01	686	32.76	832	64.02	1626	37.72	958	21.89	556	31.5	*800	10681.2	4845
36*30	900*750	29.02	737	34.49	876	67.99	1727	40.75	1035	24.41	620	31.5	*800	13448	6100
40*34	1000*850	32.76	832	38.5	978	75.98	1930	43.46	1104	26.22	666	31.5	*800	18077.6	8200
42*36	1050*900	34.49	876	40.24	1022	80	2032	45	1143	28.27	718	31.5	*800	20282.2	9200
48*40	1200*1000	38.5	978	45.98	1168	85.43	2170	56.5	1435	34.92	887	31.5	*800	33068.8	15000

* Gear operation

Full Port													
Size		D		L		H1		H2		W		Weight	
in	mm	in	mm	in	mm	in	mm	in	mm	in	mm	lb	kg
2	50	2.01	51	11.5	292	8.11	206	4.45	113	15.75	400	72.8	33
3	80	2.99	76	14.02	356	12.4	315	5.08	129	29.53	750	141.1	64
4	100	4.02	102	17.01	432	12.99	330	6.65	169	39.37	1000	257.9	117
6	150	5.98	152	22.01	559	13.58	345	5.83	148	11.81	300	628.3	285
8	200	7.99	203	25.98	660	16.34	415	8.9	226	11.81	300	996.5	452
10	250	10	254	30.98	787	16.81	427	10.59	269	19.69	*500	1622.6	736
12	300	12.01	305	32.99	838	18.31	465	11.81	300	23.62	*600	2204.6	1000
14	350	13.27	337	35	889	20.43	519	13.78	350	23.62	*600	2929.9	1329
16	400	15.24	387	39.02	991	25.12	638	15.83	402	23.62	*600	3813.9	1730
18	450	17.24	438	42.99	1092	26.89	683	17.56	446	23.62	*600	5037.5	2285
20	500	19.25	489	47.01	1194	29.45	748	19.37	492	23.62	*600	6203.7	2814
22	550	21.26	540	50.98	1295	33.62	854	20.91	531	31.5	*800	7429.5	3370
24	600	23.27	591	55	1397	36.1	917	21.89	556	31.5	*800	10846.6	4920
28	700	27.01	686	60.98	1549	37.72	958	24.41	620	31.5	*800	13359.8	6060
30	750	29.02	737	65	1651	40.75	1035	26.22	666	31.5	*800	14748.7	6690
32	800	30.75	781	70	1778	42.8	1087	26.22	666	31.5	*800	17250.9	7825
34	850	32.76	832	75.98	1930	43.46	1104	28.27	718	31.5	*800	18650.8	8460
36	900	34.49	876	82.01	2083	45	1143	27.56	700	31.5	*800	23473.8	10650
40	1000	38.5	978	85	2159	56.5	1435	34.92	887	31.5	*800	32407.4	14700
42	1050	40.24	1022	85.63	2175	64.49	1638	36.34	923	31.5	*800	36177.2	16410
48	1200	45.98	1168	95.87	2435	69.49	1765	42.05	1068	31.5	*800	53351	24200

*Gear operation

3-Pcs, SPLIT BODY, SIDE ENTRY, FORGED STEEL DESIGN

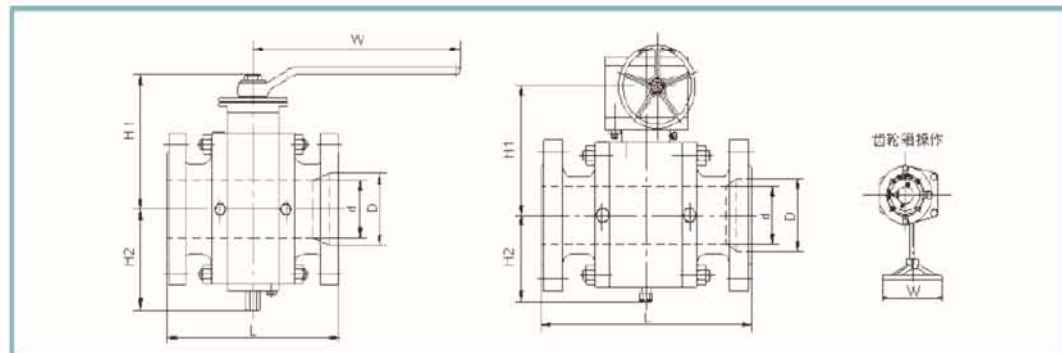

Class 600 LB

Reduced Port															
Size		d		D		L		H1		H2		W		Weight	
in	mm	in	mm	in	mm	in	mm	in	mm	in	mm	in	mm	lb	kg
3*2	80*50	2.01	51	2.99	76	14.02	356	8.11	206	4.45	113	15.75	400	103.7	47
4*3	100*80	2.99	76	4.02	102	17.01	432	12.4	315	5.08	129	29.53	750	189.6	86
6*4	150*100	4.02	102	5.98	152	22.01	559	12.99	330	6.65	169	39.37	1000	357.1	162
8*6	200*150	5.98	152	7.99	203	25.98	660	13.58	345	5.83	148	11.81	300	670.2	304
10*8	250*200	7.99	203	10	254	30.98	787	16.34	415	7.28	185	11.81	300	1181.7	536
12*10	300*250	10	254	12.01	305	32.99	838	16.81	427	8.9	226	19.69	*500	1838.6	834
14*12	350*300	12.01	305	13.27	337	35	889	18.31	465	10.59	269	23.62	*600	2403	1090
16*14	400*350	13.27	337	15.24	387	39.02	991	20.43	519	11.81	300	23.62	*600	2888	1310
18*16	450*400	15.24	387	17.24	438	42.99	1092	25.12	638	13.78	350	23.62	*600	4135.8	1875
20*18	500*450	17.24	438	19.25	489	47.01	1194	26.89	683	15.83	402	23.62	*600	5564.4	2524
22*18	550*450	17.24	438	21.26	540	50.98	1295	29.45	748	15.83	402	23.62	*600	5357.1	2430
24*20	600*500	19.25	489	23.27	591	55	1397	33.62	854	17.56	446	23.62	*600	7583.8	3440
28*24	700*600	23.27	591	27.01	686	60.98	1549	36.1	917	20.91	531	31.5	*800	9369.5	4250
30*24	750*600	23.27	591	29.02	737	65	1651	36.1	917	20.91	531	31.5	*800	10427.7	4730
34*28	850*700	27.01	686	32.76	832	75.98	1930	37.72	958	21.89	556	31.5	*800	15873	7200
36*30	900*750	29.02	737	34.49	876	82.01	2083	40.75	1035	24.41	620	31.5	*800	18959.4	8600
40*34	1000*850	32.76	832	38.5	978	85	2159	43.46	1104	26.22	666	31.5	*800	22089.9	10020
42*36	1050*900	34.49	876	40.24	1022	85.63	2175	45	1143	28.27	718	31.5	*800	24470.9	11100
48*40	1200*1000	38.5	978	45.98	1168	95.87	2435	56.5	1435	34.92	887	31.5	*800	37918.9	17200

* Gear operation

3-Pcs, SPLIT BODY, SIDE ENTRY, FORGED STEEL DESIGN

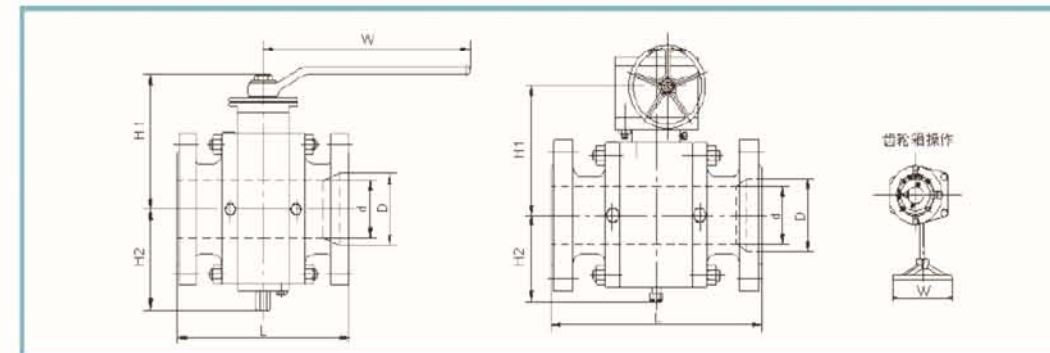

Class 900 LB

Full Port													
Size		D		L		H1		H2		W		Weight	
in	mm	in	mm	in	mm	in	mm	in	mm	in	mm	lb	kg
2	50	2.01	51	14.49	368	4.69	119	4.69	119	18.11	460	143.3	65
3	80	2.99	76	15	381	5.24	133	5.24	133	39.37	1000	202.8	92
4	100	4.02	102	17.99	457	6.93	176	6.93	176	59.06	1500	339.5	154
6	150	5.98	152	24.02	610	6.02	153	6.02	153	11.81	300	864.2	392
8	200	7.99	203	29.02	737	7.6	193	7.6	193	15.75	400	1351.4	613
10	250	10	254	32.99	838	9.25	235	9.25	235	19.69	*500	1607.8	820
12	300	12.01	305	37.99	965	11.02	280	11.02	280	23.62	*600	2480.2	1125
14	350	12.76	324	40.51	1029	12.28	312	12.28	312	23.62	*600	3549.4	1610
16	400	14.76	375	44.49	1130	14.37	365	14.37	365	23.62	*600	4431.2	2010
18	450	16.73	425	47.99	1219	16.3	414	16.3	414	23.62	*600	6194.9	2810
20	500	18.62	473	52.01	1321	18.07	459	18.07	459	23.62	*600	8730.2	3960
22	550	20.63	524	55.98	1422	19.96	507	19.96	507	31.5	*800	9722.2	4410
24	600	22.52	572	60.98	1549	21.54	547	21.54	547	31.5	*800	17901.2	8120
28	700	26.26	667	69.02	1753	22.56	573	22.56	573	31.5	*800	22491.2	10202
30	750	28.11	714	74.02	1880	25.12	638	25.12	638	31.5	*800	25617.3	11620
32	800	30	762	80	2032	27.01	686	27.01	686	31.5	*800	26679.9	12102
34	850	31.89	810	85	2159	27.09	688	27.09	688	31.5	*800	38496.5	17462
36	900	33.74	857	90	2286	29.09	739	29.09	739	31.5	*800	44431.2	20154

*Gear operation

3-Pcs, SPLIT BODY, SIDE ENTRY, FORGED STEEL DESIGN

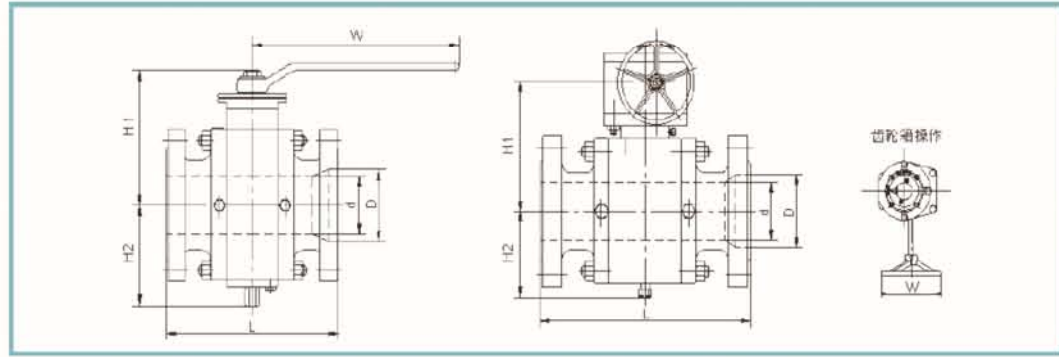

Class 900 LB

Size		d		D		L		H1		H2		W		Weight	
in	mm	in	mm	in	mm	in	mm	in	mm	in	mm	in	mm	lb	kg
3*2	80*50	2.01	51	2.99	76	15	381	8.54	217	4.69	119	18.11	460	156.5	71
4*3	100*80	2.99	76	4.02	102	17.99	457	12.87	327	5.24	133	39.37	1000	244.7	111
6*4	150*100	4.02	102	5.98	152	24.02	610	13.5	343	6.93	176	59.06	1500	471.8	214
8*6	200*150	5.98	152	7.99	203	29.02	737	14.09	358	6.02	153	11.81	300	1058.2	480
10*8	250*200	7.99	203	10	254	32.99	838	16.97	431	7.6	193	15.75	400	1433.0	650
12*10	300*250	10	254	12.01	305	37.99	965	17.44	443	9.25	235	19.69	*500	1913.6	868
14*12	350*300	12.01	305	12.76	324	40.51	1029	19.06	484	11.02	280	23.62	*600	2888	1310
16*14	400*350	12.76	324	14.76	375	44.49	1130	21.26	540	12.28	312	23.62	*600	4034.4	1830
18*16	450*400	14.76	375	16.73	425	47.99	1219	25.99	660	14.37	365	23.62	*600	4861.1	2205
20*18	500*450	16.73	425	18.62	473	52.01	1321	27.56	700	16.3	414	23.62	*600	6922.4	3140
22*20	550*450	16.73	425	20.63	524	55.98	1422	27.56	700	16.3	414	23.62	*600	7248.7	3288
24*20	600*500	18.62	473	22.52	572	60.98	1549	30.31	770	18.07	459	23.62	*600	10582	4800
28*24	700*600	22.52	572	26.26	667	69.02	1753	37.2	945	21.54	547	31.5	*800	16710.8	7580
30*24	750*600	22.52	572	28.11	714	74.02	1880	37.2	945	21.54	547	31.5	*800	17594.8	7981
34*28	850*700	26.26	667	31.89	810	85	2159	38.86	987	22.56	573	31.5	*800	24695.8	11202
48*40	1200*1000	28.11	714	33.74	857	90	2286	41.97	1066	25.12	638	31.5	*800	34508.4	15653

* Gear operation

3-Pcs, SPLIT BODY, SIDE ENTRY, FORGED STEEL DESIGN

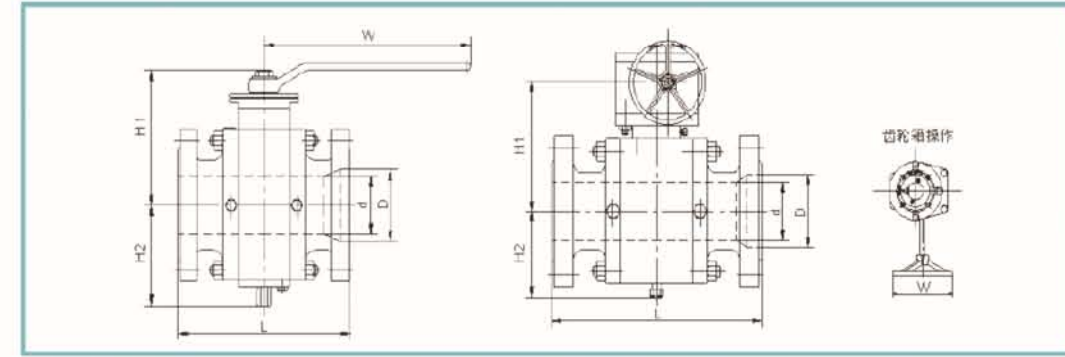

Class 1500 LB

Size		D		L		H1		H2		W		Weight	
in	mm	in	mm	in	mm	in	mm	in	mm	in	mm	lb	kg
4	100	4.02	102	21.5	546	6.54	166	6.54	166	11.81	300	571	259
6	150	5.98	152	27.75	705	7.56	192	7.56	192	15.75	400	1047.2	475
8	200	7.99	203	32.76	832	9.37	238	9.37	238	19.69	*500	1810	821
10	250	9.41	239	39.02	991	10.79	274	10.79	274	23.62	*600	4025.6	1826
12	300	11.38	289	44.49	1130	12.52	318	12.52	318	23.62	*600	4784	2170
14	350	12.52	318	49.49	1257	19.02	483	19.02	483	23.62	*600	4960.3	2250
16	400	14.25	362	54.49	1384	21.02	534	21.02	534	23.62	*600	6084.7	2760
18	450	16.02	407	60.51	1537	23.86	606	23.86	606	23.62	*600	8037.9	3646
20	500	17.99	457	65.51	1664	27.01	686	27.01	686	31.5	*800	9914	4497
22	550	19.69	500	71.5	1816	28.78	731	28.78	731	31.5	*800	12637.5	5731
24	600	21.5	546	80.43	2043	30.51	775	30.51	775	31.5	*800	15765	7151

Size		d		D		L		H1		H2		W		Weight	
in	mm	in	mm	in	mm	in	mm	in	mm	in	mm	in	mm	lb	kg
6*4	150*100	4.02	102	5.75	146	27.76	705	13.58	345	6.54	166	59.06	1500	760.6	345
8*6	200*150	5.75	146	7.64	194	32.76	832	14.37	365	7.56	192	11.81	300	1320.5	599
10*8	250*200	7.64	194	9.49	241	39.02	991	16.65	423	9.37	238	15.75	400	2636.7	1196
12*10	300*250	9.49	241	11.38	289	44.49	1130	22.05	560	10.79	274	19.69	*500	2954.1	1340
14*12	350*300	11.38	289	12.52	318	49.49	1257	23.94	608	12.52	318	23.62	*600	6424.2	2914
16*14	400*350	12.52	318	14.25	362	54.49	1304	26.06	662	19.09	485	23.62	*600	5445.3	2470
18*16	450*400	14.25	362	15.98	406	60.51	1537	31.34	796	21.02	534	23.62	*600	6503.6	2950
20*18	500*450	16.02	407	17.76	451	65.51	1664	33.43	849	23.86	606	23.62	*600	7385.4	3350
22*20	550*450	16.02	407	19.49	495	71.5	1816	33.43	849	11.93	303	23.62	*600	7936.5	3600
24*20	600*500	17.99	457	20.98	533	80.43	2043	37.95	964	27.01	686	31.5	*800	12996.8	5850

*Gear operation

3-Pcs, SPLIT BODY, SIDE ENTRY, FORGED STEEL DESIGN

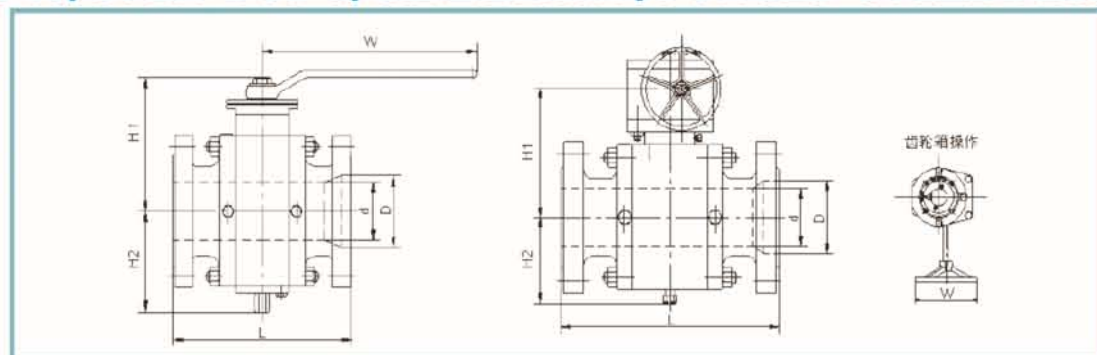

Class 2500 LB

Full Port													
Size		D		L		H1		H2		W		Weight	
in	mm	in	mm	in	mm	in	mm	in	mm	in	mm	lb	kg
2	50	1.73	44	17.76	451	9.41	239	5.63	143	15.75	*400	198.4	90
3	80	2.52	64	22.76	578	10.43	265	7.52	191	19.69	*500	440.9	200
4	100	3.5	89	26.5	673	11.1	282	7.83	199	19.69	*500	848.8	385
6	150	5.24	133	35.98	914	20.59	523	11.77	299	23.62	*600	1715.2	778
8	200	7.13	181	40.24	1022	24.21	651	14.88	375	27.56	*700	2980.6	1352
10	250	8.86	225	50	1270	23.03	585	17.13	435	29.92	*760	4711.2	2137
12	300	10.51	267	55.99	1422	27.72	704	21.26	540	29.92	*760	7202.4	3267

* Gear operation

TOP ENTRY, TRUNNION DESIGN

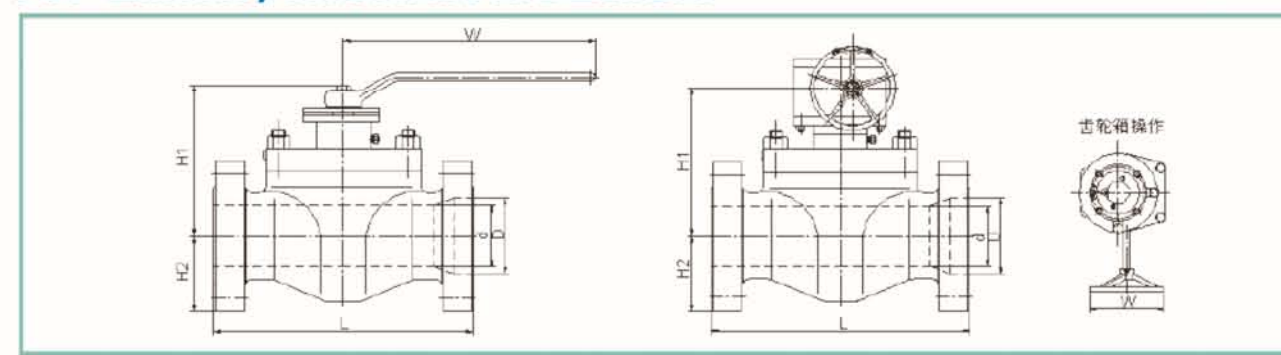

Class 600 LB

Full Port													
Size		D		L		H1		H2		W		Weight	
in	mm	in	mm	in	mm	in	mm	in	mm	in	mm	lb	kg
1-1/2	40	1.5	38	9.49	241	8.23	209	2.76	70	15.75	400	66.1	30
2	50	2.01	51	11.5	292	7.68	195	4.33	110	15.75	400	83.8	38
3	80	2.99	76	14.02	356	9.45	240	4.33	110	29.53	750	176.4	80
4	100	4.02	102	17.01	432	11.02	280	6.89	175	39.37	1000	330.7	150
6	150	5.98	152	22.01	559	12.01	305	7.68	195	11.81	*300	652.6	296
8	200	7.99	203	25.98	660	15.75	400	11.02	280	11.81	*300	965.6	438
10	250	10	254	30.98	787	17.13	435	11.22	285	19.69	*500	1325	601
12	300	12.01	305	32.99	838	17.32	440	12.6	320	23.62	*600	1377.9	625
14	350	13.27	337	35	889	19.88	505	13.39	340	23.62	*600	2711.6	1230
16	400	15.24	387	39.02	991	23.23	590	16.14	410	23.62	*600	3384	1535
18	450	17.24	438	42.99	1092	27.56	700	17.52	445	23.62	*600	4706.8	2135
20	500	19.25	489	47.01	1194	30.51	775	20.08	510	23.62	*600	5820.1	2640
24	600	23.27	591	55	1397	33.07	840	25.2	640	23.62	*600	8730.2	3960

Reduced Port															
Size		d		D		L		H1		H2		W		Weight	
in	mm	in	mm	in	mm	in	mm	in	mm	in	mm	in	mm	lb	kg
2*1-1/2	50*40	1.5	38	2.01	51	11.5	292	8.23	209	2.76	70	15.75	400	88.2	40
3*2	80*50	2.01	51	2.99	76	14.02	356	7.68	195	4.33	110	15.75	400	119	54
4*3	100*80	2.99	76	4.02	102	17.01	432	9.45	240	4.33	110	29.53	750	218.3	99
6*4	150*100	4.02	102	5.98	152	22.01	559	11.02	280	6.89	175	39.37	1000	467.4	212
8*6	200*150	5.75	146	7.99	203	25.98	660	12.01	305	7.68	195	11.81	*300	670.2	304
10*8	250*200	7.64	194	10	254	30.98	787	15.75	400	11.02	280	11.81	*300	1124.3	510
12*10	300*250	9.49	241	12.01	305	32.99	838	17.13	435	11.22	285	19.69	*500	1988.5	902
14*12	350*300	11.38	289	13.27	337	35	889	17.32	440	12.6	320	23.62	*600	2403	1090
16*14	400*350	12.52	318	15.24	387	39.02	991	19.88	505	13.39	340	23.62	*600	2888	1310
18*16	450*400	14.25	362	17.24	438	42.99	1092	23.23	590	16.14	410	23.62	*600	3615.5	1640
20*18	500*450	16.02	407	19.25	489	47.01	1194	27.56	700	17.52	445	23.62	*600	5357.1	2430
24*20	600*500	17.99	457	23.27	591	55	1397	30.51	775	20.08	510	23.62	*600	7583.8	3440

*Gear operation

TOP ENTRY, TRUNNION MOUNTED DESIGN

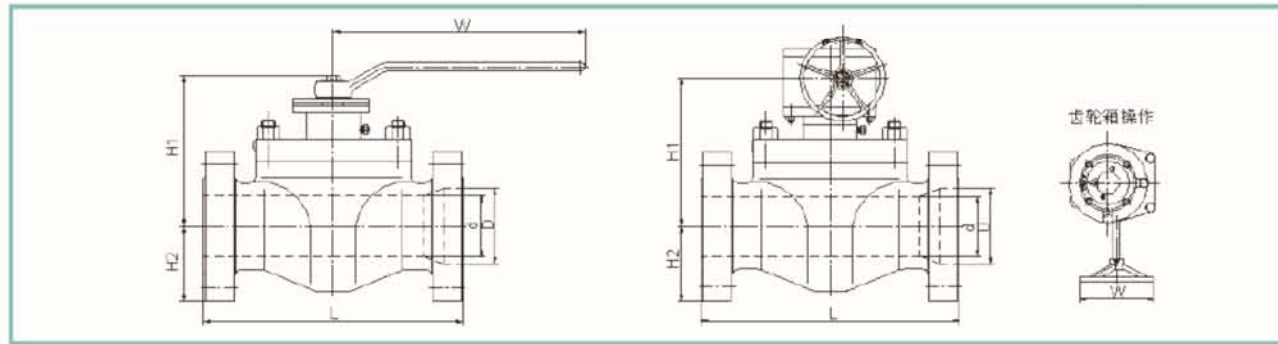

Class 90 LB

Full Port													
Size		D		L		H1		H2		W		Weight	
in	mm	in	mm	in	mm	in	mm	in	mm	in	mm	lb	kg
1-1/2	40	1.5	38	12.01	305	8.46	215	3.15	80	15.75	400	88.2	40
2	50	2.01	51	14.49	368	7.87	200	4.72	120	29.53	750	114.6	52
3	80	2.99	76	15	381	9.45	240	5.12	130	39.37	1000	191.8	87
4	100	4.02	102	17.99	457	11.02	280	6.89	175	59.06	1500	352.7	160
6	150	5.98	152	24.02	610	13.78	350	8.66	220	11.81	*300	848.8	385
8	200	7.99	203	29.02	737	15.35	390	10.24	260	15.75	*400	1234.6	560
10	250	10	254	32.99	838	18.9	480	12.2	310	23.62	*600	1807.8	820
12	300	12.01	305	37.99	965	21.18	538	16.14	410	23.62	*600	2480.2	1125

Reduced Port															
Size		d		D		L		H1		H2		W		Weight	
in	mm	in	mm	in	mm	in	mm	in	mm	in	mm	in	mm	lb	kg
2*1-1/2	50*40	1.5	38	2.01	51	14.49	368	8.46	215	3.15	80	15.75	400	97	44
3*1-1/2	80*40	2.01	51	2.99	76	15	381	7.87	200	4.72	120	29.53	750	123.5	56
4*3	100*80	2.99	76	4.02	102	17.99	457	9.45	240	9.45	240	39.37	1000	207.2	94
6*4	150*100	4.02	102	5.98	152	24.02	610	11.02	280	11.02	280	59.06	1500	498.2	226
8*6	200*150	5.98	152	7.99	203	29.02	737	13.78	350	13.78	350	11.81	*300	1058.2	480
10*8	250*200	7.99	203	10	254	32.99	838	15.35	390	15.35	390	15.75	*400	1433	650
12*10	300*250	10	254	12.01	305	37.99	965	18.9	480	18.9	480	23.62	*600	1913.6	868

* Gear operation

TOP ENTRY, TRUNNION MOUNTED DESIGN

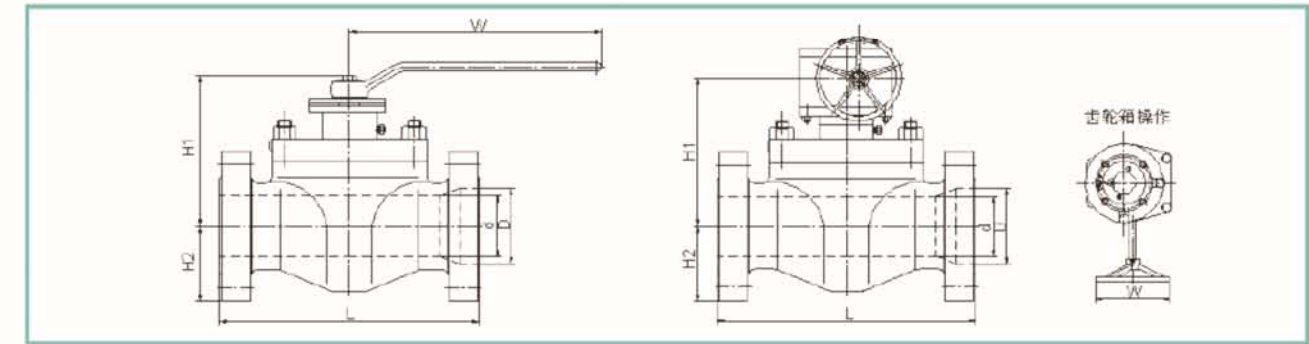

Class 1500 LB

Full Port													
Size		D		L		H1		H2		W		Weight	
in	mm	in	mm	in	mm	in	mm	in	mm	in	mm	lb	kg
1-1/2	40	1.5	38	12.01	305	8.66	220	3.54	90	15.75	400	88.2	40
2	50	2.01	51	14.49	368	8.07	205	4.72	120	29.53	750	132.3	60
3	80	2.99	76	18.5	470	8.27	210	4.92	125	39.37	1000	253.5	115
4	100	4.02	102	21.5	546	9.65	245	6.30	160	11.81	*300	427.7	194
6	150	5.75	146	27.76	705	13.19	335	10.04	255	15.75	*400	1278.7	580
8	200	7.64	194	32.76	832	16.81	427	13.39	340	19.69	*500	1657.8	752
10	250	9.49	241	39.02	991	19.76	502	15.00	381	23.62	*600	2634.5	1195
12	300	11.38	289	44.49	1130	20.98	533	17.24	438	23.62	*600	4784	2170

Reduced Port															
Size		d		D		L		H1		H2		W		Weight	
in	mm	in	mm	in	mm	in	mm	in	mm	in	mm	in	mm	lb	kg
2*1-1/2	50*40	1.5	38	2.01	51	14.49	368	8.66	220	3.54	90	15.75	400	97	44
3*1-1/2	80*40	2.01	51	2.99	76	18.5	470	8.07	205	4.72	120	29.53	750	180.8	82
4*3	100*80	2.99	76	4.02	102	21.5	546	8.27	210	4.92	125	39.37	1000	330.7	150
6*4	150*100	4.02	102	5.75	146	27.76	705	9.65	245	6.3	160	11.81	*300	650.4	295
8*6	200*150	5.75	146	7.64	194	32.76	832	13.19	335	10.04	255	15.75	*400	1521.2	690
10*8	250*200	7.64	194	9.49	241	39.02	991	16.81	427	13.39	340	19.69	*500	2050.3	930
12*10	300*250	9.49	241	11.38	289	44.49	1130	19.76	502	15.00	381	23.62	*600	2954.1	1340

* Gear operation

FULLY WELDED, TRUNNION MOUNTED DESIGN

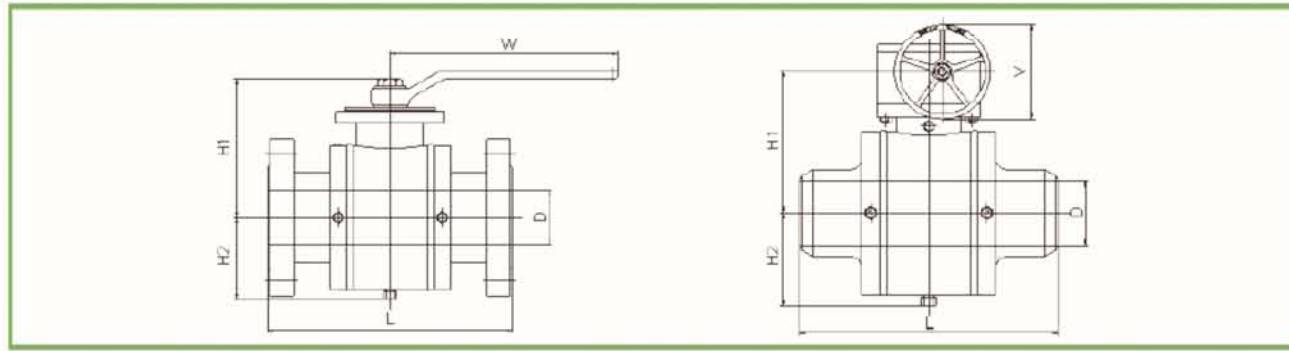

Class 150 LB

Size		D		L				H1		H2		W		V		Weight	
in	mm	in	mm	RF		BW		in	mm	in	mm	in	mm	in	mm	lb	kg
2	50	2.01	51	7.01	178	8.5	216	7.87	200	4.45	113	10.43	265			68.3	31
3	80	2.99	76	7.99	203	11.14	283	11.81	300	5.08	129	15.75	400			152.1	69
4	100	4.02	102	9.02	229	12.01	305	12.4	315	6.65	169	29.53	750			200.6	91
6	150	5.98	152	15.51	394	17.99	457	13.19	335	5.83	148			11.81	300	465.2	211
8	200	7.99	203	17.99	457	20.51	521	15.94	405	7.28	185			11.81	300	828.9	376
10	250	10	254	20.98	533	22.01	559	16.81	427	8.9	226			11.81	300	1190.5	540
12	300	12.01	305	24.02	610	25.00	635	18.31	465	10.59	269			19.69	500	1682.1	763
14	350	13.27	337	27.01	686	30.00	762	19.92	506	11.81	300			23.62	600	1984.1	900
16	400	15.24	387	30	762	32.99	838	24.49	622	13.78	350			23.62	600	2866	1300
18	450	17.24	438	34.02	864	35.98	914	26.22	666	15.83	402			23.62	600	3780.9	1715
20	500	19.25	489	35.98	914	40.00	1016	28.74	730	17.56	446			23.62	600	4607.6	2090
22	550	21.26	540	40	1016	42.01	1067	32.8	833	19.37	492			23.62	600	4894.2	2220
24	600	23.27	591	42.01	1067	45.00	1143	35.24	895	20.91	531			31.5	800	6371.3	2890
28	700	27.01	686	49.02	1245	52.99	1345	36.81	935	21.89	556			31.5	800	10086	4575
30	750	29.02	737	50.98	1295	55.00	1397	39.76	1010	24.41	620			31.5	800	12323.6	5590
32	800	30.75	781	54.02	1372	60.00	1524	41.73	1060	26.22	666			31.5	800	13756.6	6240
34	850	32.76	832	57.99	1473	64.02	1626	42.4	1077	26.22	666			31.5	800	16247.8	7370
36	900	34.49	876	60	1524	67.99	1727	43.9	1115	28.27	718			31.5	800	18595.7	8435
40	1000	38.5	978	69.02	1753	77.01	1956	55.12	1400	34.92	887			31.5	800	24691.4	11200
42	1050	40.24	1022	73.03	1855	82.01	2083	62.91	1598	36.34	923			31.5	800	28769.8	13050
48	1200	45.98	1168	84.02	2134	84.02	2134	67.8	1722	42.05	1068			31.5	800	41887.1	19000
54	1350	51.73	1314	97.99	2489	97.99	2489			45.87	1165			31.5	800	71869.5	32600
56	1400	53.62	1362	101.3	2573	101.3	2573			50.39	1280			31.5	800	80467.4	36500
60	1500	57.52	1461							58.9	1496			31.5	800	86199.3	39100

* Gear operation

FULLY WELDED, TRUNNION MOUNTED DESIGN

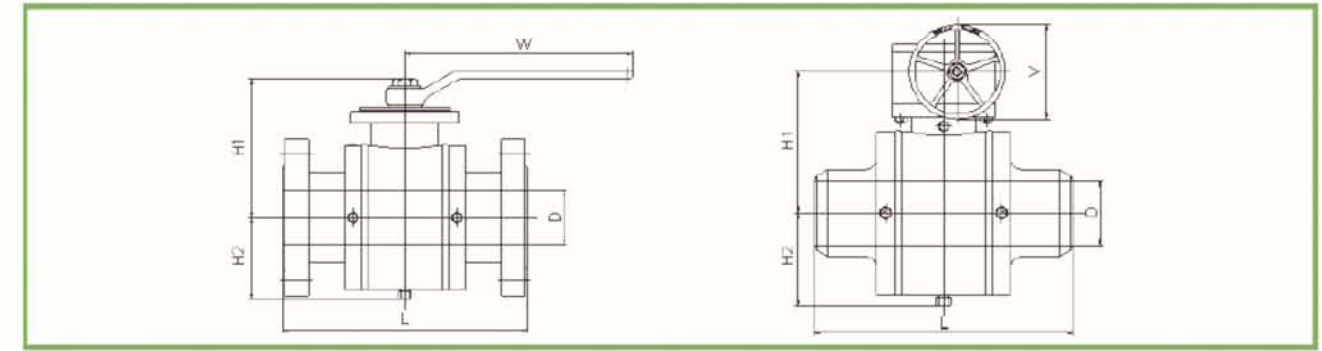

Class 300 LB

Size		D		L				H1		H2		W		V		Weight	
in	mm	in	mm	RF		BW		in	mm	in	mm	in	mm	in	mm	lb	kg
2	50	2.01	51	8.5	216	8.5	216	7.87	200	4.45	113	10.43	265			68.3	31
3	80	2.99	76	11.14	283	11.14	283	11.81	300	5.08	129	15.75	400			152.1	69
4	100	4.02	102	12.01	305	12.01	305	12.4	315	6.65	169	29.53	750			200.6	91
6	150	5.98	152	15.87	403	15.87	403	13.19	335	5.83	148			11.81	300	465.2	211
8	200	7.99	203	20.51	521	20.51	521	15.94	405	7.28	185			11.81	300	828.9	376
10	250	10	254	22.01	559	22.01	559	16.81	427	8.9	226			11.81	300	1190.5	540
12	300	12.01	305	25.00	635	25.00	635	18.31	465	10.59	269			19.69	500	1682.1	763
14	350	13.27	337	30.00	762	30.00	762	19.92	506	11.81	300			23.62	600	1984.1	900
16	400	15.24	387	32.99	838	32.99	838	24.49	622	13.78	350			23.62	600	2866	1300
18	450	17.24	438	35.98	914	35.98	914	26.22	666	15.83	402			23.62	600	3780.9	1715
20	500	19.25	489	30.02	991	30.02	991	28.74	730	17.56	446			23.62	600	4607.6	2090
22	550	21.26	540	42.99	1092	42.99	1092	32.8	833	19.37	492			23.62	600	4894.2	2220
24	600	23.27	591	45.00	1143	45.00	1143	35.24	895	20.91	531			31.5	800	6371.3	2890
28	700	27.01	686	52.99	1346	52.99	1346	36.81	935	21.89	556			31.5	800	10086	4575
30	750	29.02	737	55.00	1397	55.00	1397	39.76	1010	24.41	620			31.5	800	12323.6	5590
32	800	30.75	781	60.00	1524	60.00	1524	41.73	1060	26.22	666			31.5	800	13756.6	6240
34	850	32.76	832	64.02	1626	64.02	1626	42.4	1077	26.22	666			31.5	800	16247.8	7370
36	900	34.49	876	67.99	1727	67.99	1727	43.9	1115	28.27	718			31.5	800	18595.7	8435
40	1000	38.5	978	77.01	1956	77.01	1956	55.12	1400	34.92	887			31.5	800	24691.4	11200
42	1050	40.24	1022	82.01	2083	82.01	2083	62.91	1598	36.34	923			31.5	800	28769.8	13050
48	1200	45.98	1168	85.43	2170	85.43	2170	67.8	1722	42.05	1068			31.5	800	41887.1	19000
54	1350	51.73	1314							45.87	1165			31.5	800	71869.5	32600
56	1400	53.62	1362	100.12	2543	100.12	2543			50.39	1280			31.5	800	80467.4	36500
60	1500	57.52	1461	103.43	2627	103.43	2627			58.9	1496			31.5	800	86199.3	39100

* Gear operation

FULLY WELDED, TRUNNION MOUNTED DESIGN

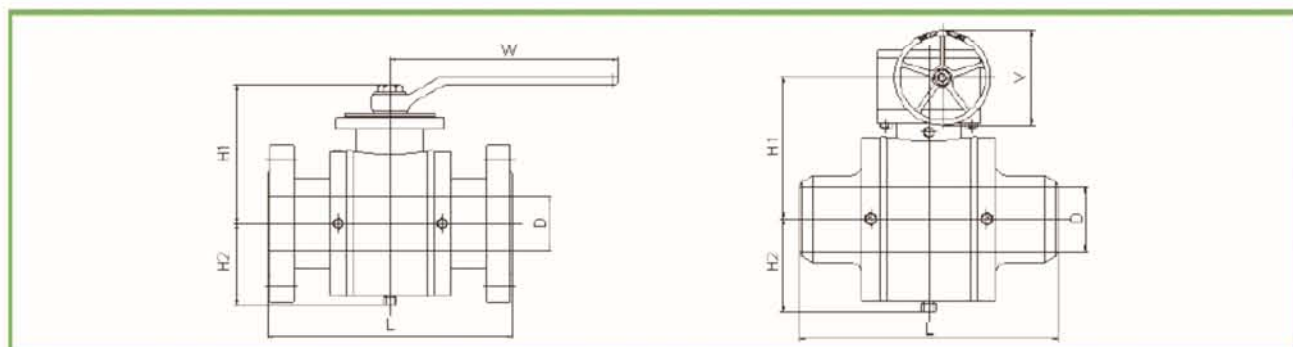

Class 400 LB

Table with 17 columns: Size, D (in, mm), L (RF, BW), H1, H2, W, V, Weight (lb, kg). Rows 2-60.

* Gear operation

FULLY WELDED, TRUNNION MOUNTED DESIGN

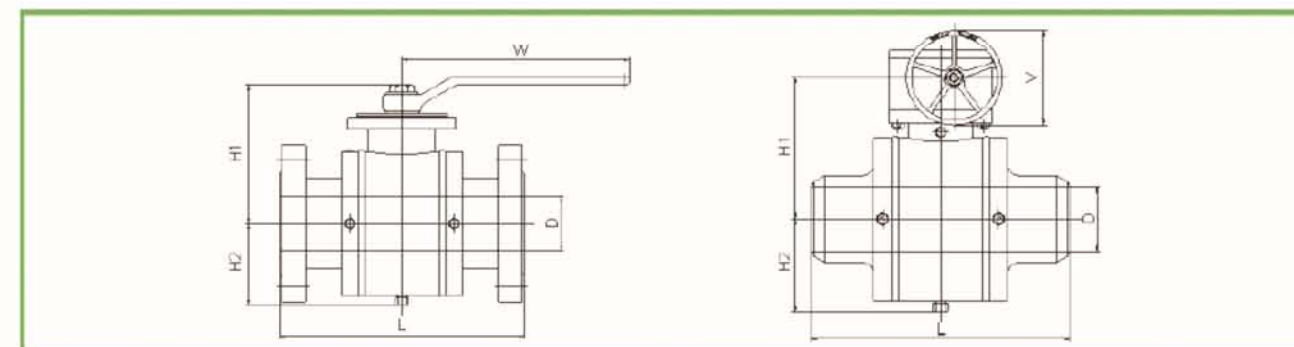

Class 600 LB

Table with 17 columns: Size, D (in, mm), L (RF, BW), H1, H2, W, V, Weight (lb, kg). Rows 2-60.

* Gear operation

FULLY WELDED, TRUNNION MOUNTED DESIGN

FULLY WELDED, TRUNNION MOUNTED DESIGN

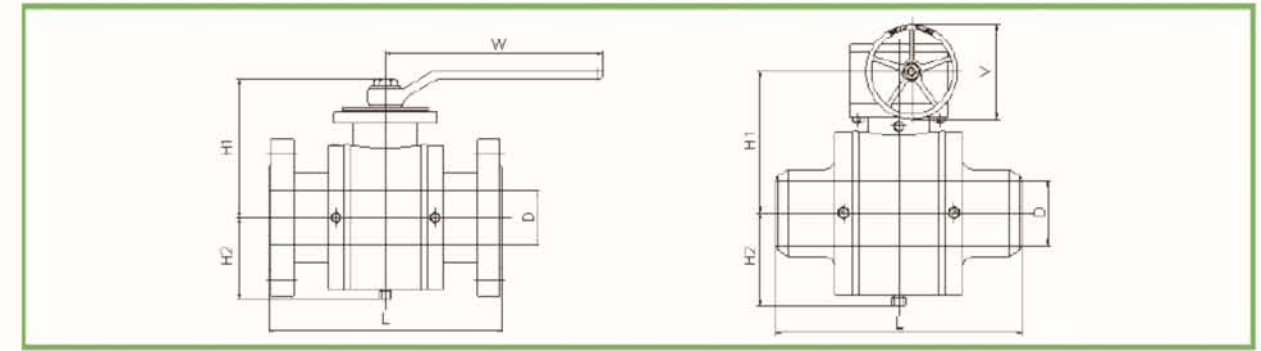
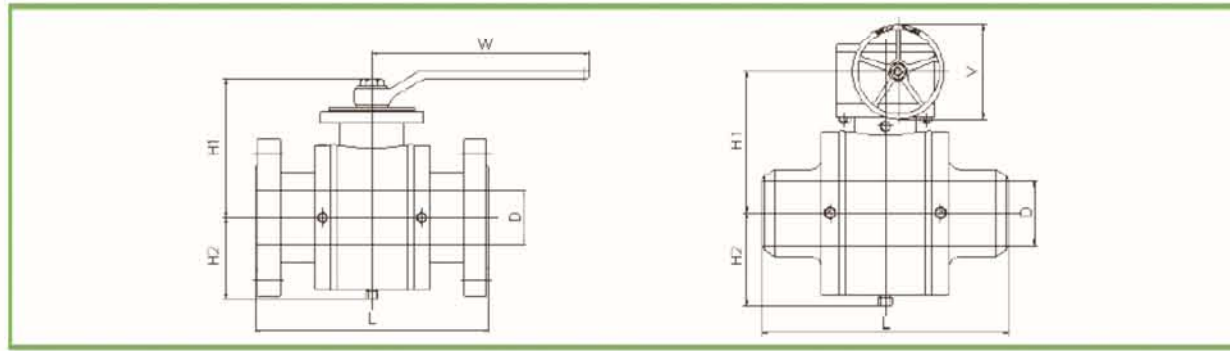

Class 900 LB

Class 1500 LB

Full Port																			
Size		D		L						H1		H2		W		V		Weight	
				RF		BW		RTJ											
in	mm	in	mm	in	mm	in	mm	in	mm	in	mm	in	mm	in	mm	in	mm	lb	kg
2	50	2.01	51	14.49	368	14.49	368	14.61	371	8.54	217	4.69	119	18.11	460			114.6	52
3	80	2.99	76	15.00	381	15.00	381	15.12	384	12.87	327	5.24	133	39.37	1000			191.8	87
4	100	4.02	102	17.99	457	17.99	457	18.11	460	13.50	343	6.93	176					352.7	160
6	150	5.98	152	24.02	610	24.02	610	24.13	613	14.09	358	6.02	153			11.81	300	848.8	385
8	200	7.99	203	29.02	737	29.02	737	29.13	740	16.97	431	7.60	193			11.81	300	1234.6	560
10	250	10.00	254	32.99	838	32.99	838	33.11	841	17.44	443	9.25	235			19.69	500	1807.8	820
12	300	12.01	305	37.99	965	37.99	965	38.11	968	19.06	484	11.02	280			23.62	600	2480.2	1125
14	350	12.76	324	40.51	1029	40.51	1029	40.87	1038	21.26	540	12.28	312			23.62	600	3549.4	1610
16	400	14.76	375	44.49	1130	44.49	1130	44.88	1140	25.99	660	14.37	365			23.62	600	4431.2	2010
18	450	16.73	425	47.99	1219	47.99	1219	48.50	1232	27.56	700	16.30	414			23.62	600	6194.9	2610
20	500	18.62	473	52.01	1321	52.01	1321	52.52	1334	30.31	770	18.07	459			23.62	600	7627.9	3460
22	550	20.63	524							34.65	880	19.96	507			31.5	800	9722.2	4410
24	600	22.52	572	60.98	1549	60.98	1549	61.73	1568	37.20	945	21.54	547			31.5	800	12118.6	5497
28	700	26.26	667							38.86	987	22.56	573			31.5	800	22491.2	10202
30	750	28.11	714	74.02	1880					41.97	1066	25.12	638			31.5	800	25224.9	11442
32	800	30.00	762	80.00	2032					44.09	1120	27.01	686			31.5	800	26679.9	12102
34	850	31.89	810	85.00	2159					44.76	1137	27.09	688			31.5	800	38496.5	17462
36	900	33.74	857	90.00	2286					46.34	1177	29.09	739			31.5	800	44431.2	20154

Full Port																			
Size		D		L						H1		H2		W		V		Weight	
				RF		BW		RTJ											
in	mm	in	mm	in	mm	in	mm	in	mm	in	mm	in	mm	in	mm	in	mm	lb	kg
2	50	2.01	51	14.49	368	14.49	368	14.61	371	8.7	221	5.12	130	29.53	750			132.3	60
3	80	2.99	76	18.5	470	18.5	470	18.62	473	11.69	297	5.98	152			11.81	300	253.5	115
4	100	4.02	102	21.50	546	21.50	546	21.61	549	13.58	345	6.54	166			11.81	300	427.7	194
6	150	5.75	146	27.76	705	27.76	705	27.99	711	14.37	365	7.56	192			15.75	400	1278.7	580
8	200	7.64	194	32.76	832	32.76	832	33.11	841	16.65	423	9.37	238			19.69	500	1657.8	752
10	250	9.49	241	39.02	991	39.02	991	39.37	1000	22.05	560	10.79	274			23.62	600	2634.5	1195
12	300	11.38	289	44.49	1130	44.49	1130	45.12	1146	23.94	608	12.52	318			23.62	600	4784.0	2170
14	350	12.52	318	49.49	1257	49.49	1257	50.24	1276	26.06	662	19.02	483			23.62	600	4960.3	2250
16	400	14.45	362	54.49	1384	54.49	1384	55.39	1407	31.34	796	21.02	534			23.62	600	6084.7	2760
18	450	16.02	407	60.51	1537	60.51	1537	61.38	1559	33.43	849	23.86	606			23.62	600	8037.9	3646
20	500	17.99	457	65.51	1664	65.51	1664	66.38	1686	37.95	964	27.01	686			31.5	800	9914.0	4497
22	550	19.49	495	71.50	1816	71.50	1816			40.35	1025	28.78	731			31.5	800	12634.5	5731
24	600	21.02	534	80.43	2043	80.43	2043	81.54	2071	41.93	1065	30.51	775			31.5	800	15765.0	7151

Class 2500 LB

Full Port																			
Size		D		L						H1		H2		W		V		Weight	
				RF		BW		RTJ											
in	mm	in	mm	in	mm	in	mm	in	mm	in	mm	in	mm	in	mm	in	mm	lb	kg
2	50	1.73	44	17.76	451	17.76	451	17.87	454	9.06	230	4.76	121	29.53	750	11.81	300	132.3	60
3	80	2.52	64	22.76	578	22.76	578	22.99	584	11.18	284	5.75	146			15.75	400	253.5	115
4	100	3.50	89	26.50	673	26.50	673	26.89	683	11.93	303	6.46	164			15.75	400	427.7	194
6	150	5.24	133	35.98	914	35.98	914	36.50	927	15.51	394	8.66	220			23.62	600	1278.7	580
8	200	7.13	181	40.24	1022	40.24	1022	40.87	1038	19.21	488	12.28	312			23.62	600	1657.8	752
10	250	8.86	225	50.00	1270	50.00	1270	50.87	1292	23.62	600	16.73	425			23.62	600	2634.5	1195
12	300	10.51	267	55.98	1422	55.98	1422	56.89	1445	34.33	872	24.76	629			29.92	760	4784.0	2170

* Gear operation

* Gear operation

Flow Coefficient (Cv Value) specification

Size	150LB	300LB	600LB	900LB	1500LB
1/2	25	25	20	16	16
3/4	56	56	48	34	34
1	95	95	64	55	55
1-1/2	308	308	308	165	165
2	500	430	370	320	320
3	1360	1100	1020	920	820
4	2500	2000	1850	1760	1600
6	5300	5250	4400	4300	4150
8	10750	10100	8450	8475	8010
10	17500	16820	14250	14160	13220
12	26750	25950	22550	21200	18800
14	31850	30900	28500	26700	24180
16	44000	42600	38150	36600	33150
18	58000	55870	51150	49000	45703
20	75500	72500	68500	64600	69750
22	91770	86850	80150		
24	113400	109340	98860		

Note:

- ① All sizes are in full port.
- ② Pressure Rate as per ASME B16.34 standard.

Pressure Temperature Chart

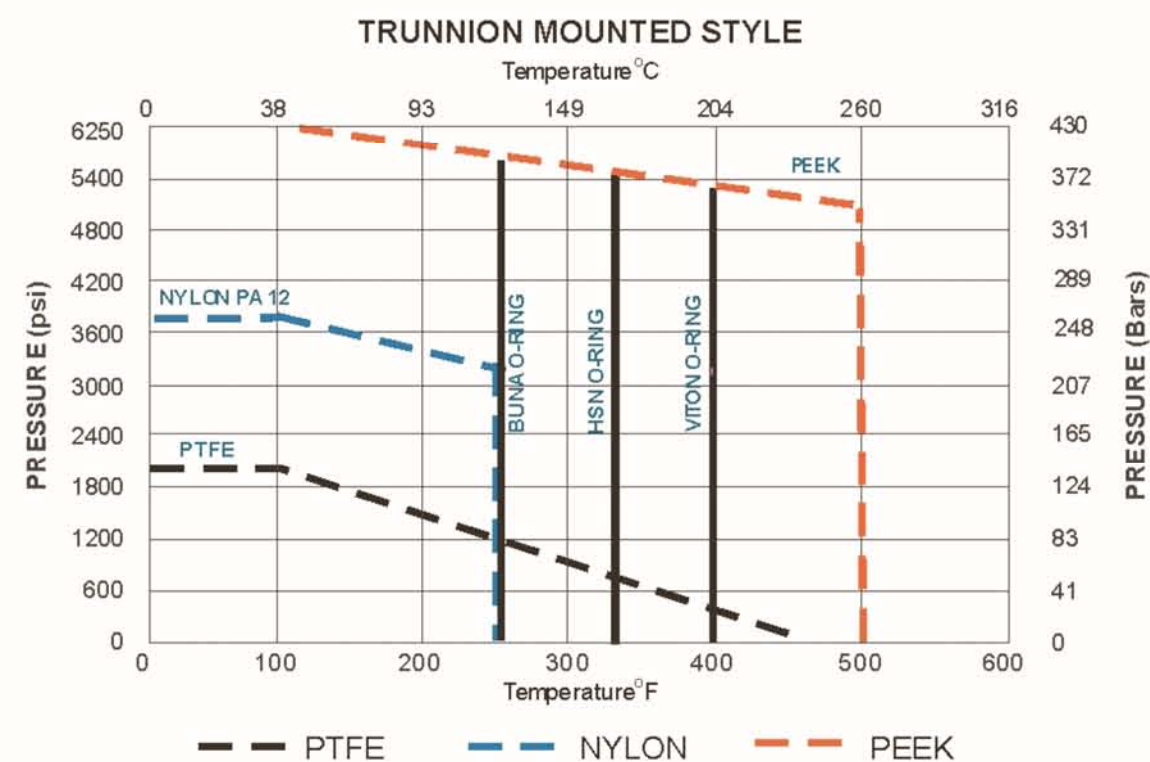

Above ratings are for soft seal components. Please consult ASME B16.34 for Body and Closure Pressure /Temperature ratings.